



GUAM POWER AUTHORITY
AGANA, GUAM

SPECIFICATION No. E-005

REVISION: 4
July 28, 2009

PREPARED BY THE ENGINEERING DEPT.

GUAM POWER AUTHORITY
P.O. BOX 2977
AGANA, GUAM 96932

TRANSMISSION & DISTRIBUTION SPECIFICATION

SPECIFICATION NO. E-005

FOR

**HIGH PRESSURE SODIUM LUMINAIRES
AND MAST ARMS**

EFFECTIVE DATE: 10/29/09

ISSUED: 

APPROVED: 



GUAM POWER AUTHORITY
AGANA, GUAM

SPECIFICATION No. E-005

PAGE 1 OF 8

REVISION: 4
July 28, 2009

PREPARED BY THE ENGINEERING DEPT.

HIGH PRESSURE SODIUM LUMINAIRES AND MAST ARMS

TABLE OF CONTENTS

SECTION		PAGE
1.0	Scope	2
2.0	Applicable Publications	2
3.0	Deviations and Non-conformance Requirements	2
4.0	Ratings	2
5.0	Design and Construction	3
6.0	Quality Control	8
7.0	Packing and Shipping	8

EFFECTIVE DATE: 10/23/09

ISSUED: 

APPROVED: 



1.0 SCOPE

- 1.1 This specification covers GPA requirements for High Pressure Sodium (HPS) luminaires and mast arms used for street lighting and private outdoor lighting.
- 1.2 The High Pressure Sodium (HPS) luminaires and mast arms are intended for use in tropical weather conditions with a corrosive sea air atmosphere, sustained winds of 155 miles per hour with gusts to 180 miles per hour and subject to moderate to severe earthquakes.

2.0 APPLICABLE PUBLICATIONS

The equipment covered by this specification shall be designed, manufactured, assembled, and tested in accordance with ANSI-IESRP-8-1998, IES LM-31, ANSI C33.31, and NEMA SH-17-1998 standards.

3.0 DEVIATIONS AND NON-CONFORMANCE REQUIREMENTS

- 3.1 Deviations from this specification or changes in the material or design after the purchase order has been placed must be approved by the GPA Engineering department and acknowledged by a Purchase Order Amendment issued by GPA.
- 3.2 Units received with deviations or non-conformances that are not acknowledged per Section 3.1 are subject to rejection. The Supplier of rejected units is responsible for any corrective action including but not limited to materials, labor and transportation necessary to dispose of or make the units conform to the specification.
- 3.3 Notification of defective units discovered before or after installation that are believed to be inherent to manufacturing problems or workmanship shall be made and forwarded to the Supplier. The description of the item, documentation of the problem and the described information, disposition and/or follow-up (as appropriate) that GPA expects from the Supplier will be specified. The Supplier's response shall be made within thirty (30) days unless an extension is acknowledged and approved in writing by the GPA Manager of Engineering.

4.0 RATINGS

Ratings of the HPS luminaires and lamps shall be as specified in the following table:

	150 Watt HPS Luminaire	250 Watt HPS Luminaire
BASE	MOGUL	MOGUL
BULB COATING	Clear	Clear
NOMINAL RATING	150 Watts	250 Watts

EFFECTIVE DATE: 10/23/09

ISSUED: *[Signature]*

APPROVED:



	150 Watt HPS Luminaire	250 Watt HPS Luminaire
BURNING POSITION	Horizontal	Horizontal
INITIAL LUMENS	16,000	30,000
MEAN LUMENS	14,400	27,000
RATED LIFE	24,000 hours	24,000 hours
ARC TUBE VOLTAGE	55 Volts	100 Volts
BALLAST (Type)	HPF reactor	Autoregulator
BALLAST (Volts)	120 + 5%	120 + 10%
LIGHT TYPE	IES II	IES IV

5.0 DESIGN AND CONSTRUCTION

5.1 Luminaire Housing

- 5.1.1 Luminaire housings, both upper and lower (lens holder), shall be made of precision die-cast aluminum with weather-resistant baked-on enamel finish applied by an electrostatic process.
- 5.1.2. The upper housing shall include a slip-fitter capable of accepting 1 ¼ inch to 2 inch IPS pipe without the need for a separate attachment or for rearrangement of mounting parts. The slip-fitter shall be provided with an approved stop or method to prevent contact of the pipe with electrical components inside the luminaire.
- 5.1.3 The upper and lower housings shall be joined by means of hinging and latching. Hinging shall incorporate a safety device to prevent accidental disengagement of the lower housing. Latching and unlatching shall be designed for ease of operation without the need for tools. The lens holder shall automatically align to the upper housing.
- 5.1.4 The ballast assembly module shall be connected to the upper housing by means of hinges and an interlock device. Hinging shall have provisions to prevent accidental disengagement from upper housing. The locking device shall be stainless steel.
- 5.1.5 The upper housing shall have a receptacle for connecting the twist-lock photo-electric control unit.
- 5.1.6 The design shall provide for an effective method of preventing bird entrance to the luminaire.

EFFECTIVE DATE: 10/23/09

ISSUED: 

APPROVED: 



5.2 Optical Assembly

- 5.2.1 The HPS luminaire shall include an enclosed optical assembly which provides the light distribution pattern as specified in Section 4.0, Light Type. The assembly shall consist of a reflector, refractor, gasket, and filter. The optical assembly shall be sealed and filtered. Breathing shall be only through the gasket.
- 5.2.2 The reflector shall be hard, highly polished anodic surfaced aluminum secured with spring latches for easy removal and accurate and easy positioning.
- 5.2.3 The refractor shall be prismatic borosilicate glass or polycarbonate with minimum transmittance of 90% and secured with spring latches.
- 5.2.4 The gasket shall be made of high temperature polyester fiber to filter air entering the optical assembly.

5.3 Lamp Socket

The lamp socket shall be porcelain enclosed multiple mogul-type. The lamp socket support shall be adjustable to permit changes in the light distribution pattern. The lamp socket and support shall be pre-set by the supplier to provide the light distribution pattern specified on the Purchase Order.

5.4 Lamp

- 5.4.1 The lamps shall be a 150 or 250 watt, 120V mogul base High Pressure Sodium vapor lamp as specified on the GPA Purchase Order.
- 5.4.2 The lamp shall come equipped with a scratch pad feature for tracking the installation date, removal date, and shall be marked with the purchase order number.

5.5 Ballast Assembly

- 5.5.1 The HPS luminaire shall include the ballast assembly module which may be attached to or detached from the upper housing with a screwdriver.
- 5.5.2 The ballast assembly shall be removable and replaceable by use of quick disconnect plugs.
- 5.5.3 Ballasts shall be pre-wired at the factory for 120-Volt AC operation, suitable for high ambient temperature and with a high power factor of 90%+.



GUAM POWER AUTHORITY
AGANA, GUAM

SPECIFICATION No. E-005

PAGE 5 OF 8

REVISION: 4
July 28, 2009

PREPARED BY THE ENGINEERING DEPT.

5.6 Photoelectric Control

5.6.1 The receptacle connection for the twist lock external photoelectric control unit shall include rigid weatherproof electrical and mechanical connections.

5.6.2 The external photoelectric control shall be an EEI-NEMA standard three-terminal, polarized, twist lock type.

5.6.3 The photoelectric control shall come equipped with a scratch pad feature for tracking installation date, removal date, and shall be marked with the purchase order number.

5.7 Terminal Strip

The terminal strip attached to the upper housing shall be connected so that the incoming conductors will not be in contact with the ballast assembly when the luminaire is in operation.

5.8 Mast Arm and Hardware

5.8.1 All hardware used shall be corrosion resistant.

5.8.2 The mast arm shall be a tapered oval type design using an aluminum extrusion "tongue and groove" locking system to maximize strength. The arm shall be designed to exceed the ANSI C136.13 standard specification for metal brackets for poles used in roadway lighting. (See Figure 1)

EFFECTIVE DATE: 10/23/09

ISSUED: *LS*

APPROVED: *muhammad*

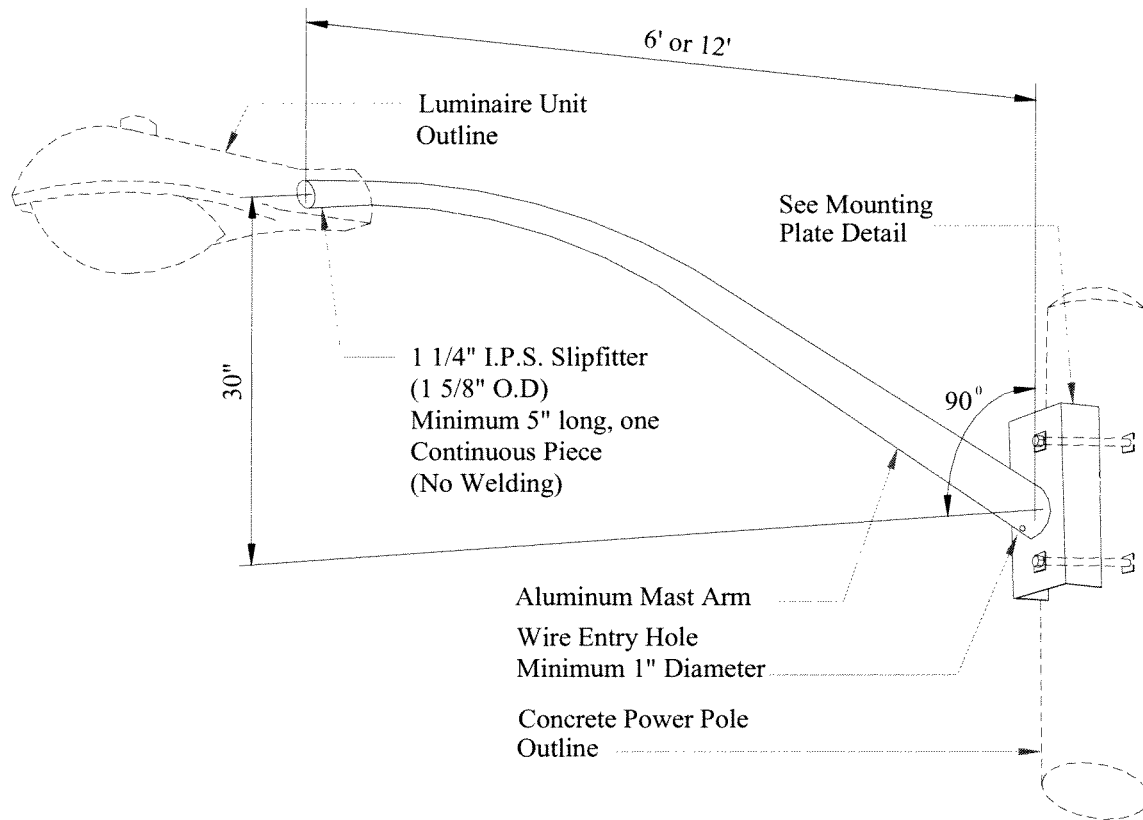

Mast Arm Elevation Detail
Figure 1

5.8.3 The mounting bracket shall be aluminum extrusion providing for maximum surface contact with the pole to increase vertical and horizontal stability. The plate shall have one 2" keyhole and one 3/4" hole for 5/8" machine bolts. (See Figure 2).

EFFECTIVE DATE: 10/23/09

ISSUED: *[Signature]*

APPROVED: *[Signature]*

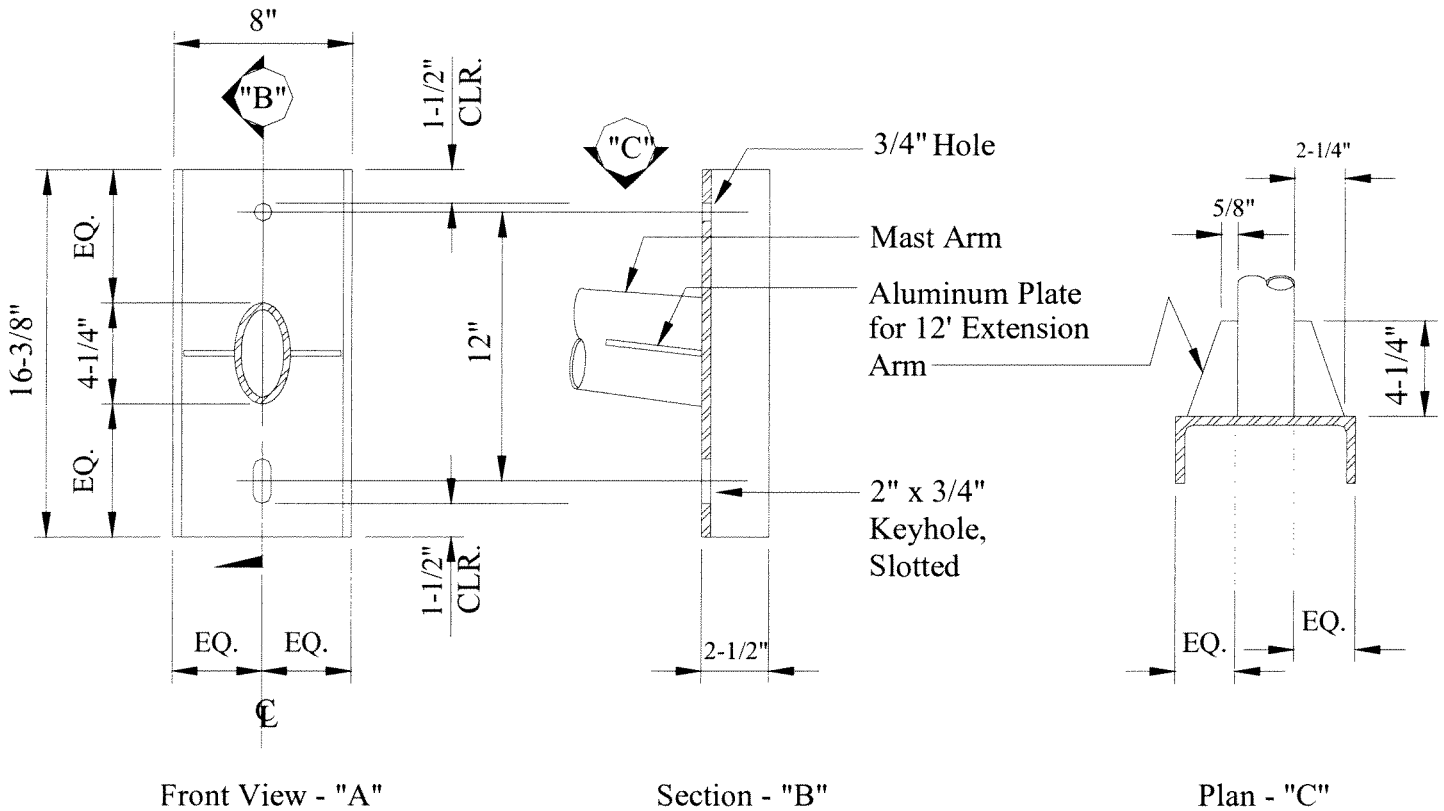

Mounting Plate Detail
Figure 2

- 5.8.4 The mast arm shall be made of three 6063-T6 aluminum alloy extrusion. The mounting plate shall be made of one 6063-T6 aluminum extrusion. The finish shall be a natural aluminum finish.
- 5.8.5 The wire entry hole location shall be through the bottom of the arm two inches from the pole mounting plate. The edges of the hole must be rounded to protect the wire from damage.
- 5.8.6 All weld connections shall be full penetration.



GUAM POWER AUTHORITY
AGANA, GUAM

SPECIFICATION No. E-005

PAGE 8 OF 8

REVISION: 4
July 28, 2009

PREPARED BY THE ENGINEERING DEPT.

5.9 Nameplate

The manufacturer shall furnish with each luminaire a nameplate attached to and inside of the upper housing. The nameplate shall include the following data:

- a. Manufacturer's name
- b. Catalog number
- c. Lamp type and ANSI code
- d. Wattage
- e. Voltage
- f. Starting and running current
- g. Complete connection diagram

6.0 QUALITY CONTROL

The Supplier shall have a quality control program to ensure compliance with the requirements of this specification. The program shall be documented and available for GPA's review if requested.

Documentation of the quality control program shall indicate where in the production and manufacturing process the quality checks are taken, describe the purpose of the checks, and describe the nature of the check, e.g. if check is visual only or if electrical or mechanical testing is used.

7.0 PACKING AND SHIPPING

- 7.1 The equipment shall be placed and crated with suitable material to prevent damage and injury during shipment and handling operations.
- 7.2 The equipment shall be securely blocked to prevent shifting during transit.
- 7.3 Instructions for handling, shipping, packaging, and storing shall be provided by the manufacturer to prevent damage, loss, deterioration, and substitution of the units.

EFFECTIVE DATE: 10/23/09

ISSUED: *[Signature]*

APPROVED: *[Signature]*