



JOSEPH T. DUENAS
CCU Chairman



JOHN M. BENAVENTE, P.E.
Interim General Manager

Telephone Nos. (671) 648-3054/55 or Facsimile (671) 648-3165

Accountability · Impartiality · Competence · Openness · Value

INVITATION FOR BID (IFB) NO.: GPA-039-15

DESCRIPTION: Miscellaneous Fixed Shunt Pole Mounted Distribution Capacitor Banks

SPECIAL REMINDERS TO PROSPECTIVE BIDDERS

Bidders are reminded to read the Sealed Bid Solicitation and Instructions, and General Terms and Conditions attached to the IFB to ascertain that all of the following requirements checked below are submitted in the bid envelope, **one (1) original, and (2) duplicates**, at the date and time for bid opening.

- (XX) BID GUARANTEE (15%) May be in the form of;
Reference #11 on the General Terms and Conditions
- a. Cashier's Check or Certified Check (**NOTE: Cashier's Check or Certified Check Refunds will be ONLY be made out to the name of the Bidder.**)
 - b. Letter of Credit or
 - c. Surety Bond – Valid only if accompanied by:
 1. Current Certificate of Authority issued by the Insurance Commissioner;
 2. Power of Attorney issued by the Surety to the Resident General Agent;
 3. Power of Attorney issued by two (2) major officers of the Surety to whomever is signing on their behalf.

() STATEMENT OF QUALIFICATION;

() SAMPLES;

(XX) BROCHURES/DESCRIPTIVE LITERATURE;

(XX) AFFIDAVIT OF DISCLOSURE OF MAJOR SHAREHOLDERS – Affidavits must comply with the following requirements:

- a. The affidavit must be signed within 60 days of the date the bid is due;
- b. Date of signature of the person authorized to sign the bid and the notary date must be the same.
- c. First time affidavit **must** be an **original** – If copy, indicate Bid Number/Agency where original can be obtained.

(XX) NON-COLLUSION AFFIDAVIT;

(XX) NO GRATUITIES OR KICKBACKS AFFIDAVIT;

(XX) ETHICAL STANDARDS AFFIDAVIT;

(XX) WAGE DETERMINATION AFFIDAVIT;

(XX) RESTRICTIONS AGAINST SEX OFFENDERS AFFIDAVIT;

(XX) OTHER REQUIREMENTS:

A Guam Business License and/or Contractor's License with proof of Employer Identification Number (EIN) is not required in order to provide a proposal for this engagement, but is a pre-condition for entering into a contract with the Authority. Bidders MUST comply with PL 26-111 dated June 18, 2002, PL 28-165 dated January 04, 2007 and Wage Determination under the Service Contract Act (www.wdol.gov). Additionally, upon award the successful bidder must provide to GPA the most recently issued Wage Determination by the US Dept. of Labor.

The reminder must be signed and returned in the bid envelope together with the bid. Failure to comply with the above requirements will mean a disqualification and rejection of the bid.

On this _____ day of _____ 2015, I, _____
authorized representative of _____ acknowledge receipt of this
special reminder to prospective bidders with the above referenced IFB.

Bidder Representative's Signature

INVITATION FOR BID

ISSUING OFFICE:
Guam Power Authority
Procurement Management Materials Supply
Gloria B. Nelson Public Service Building
688 Route 15, Mangilao, Guam 96913

J. M. Benavente 5-11-15
JOHN M. BENAVENTE, P.E. DATE
Interim General Manager

J. M. Benavente

DATE ISSUED: 05/12/2015 BID INVITATION NO.: GPA-039-15

BID FOR: Miscellaneous Fixed Shunt Pole Mounted Distribution Capacitor Banks

SPECIFICATION: See Attached

DESTINATION: See Attached

REQUIRED DELIVERY DATE: 4-6 Weeks ARO

INSTRUCTIONS TO BIDDERS:

INDICATE WHETHER: INDIVIDUAL PARTNERSHIP CORPORATION

INCORPORATED IN: _____

This bid shall be submitted in duplicate and sealed to the issuing office above no later than (Time) 3:00 P.M.,
Date: 05/26/15 and shall be publicly opened. Bid submitted after the time and date specified above
shall be rejected. See attached General Terms and Conditions and Sealed Bid Solicitation for details.

The undersigned offers and agrees to furnish within the time specified, the articles and services at the price stated opposite
the respective items listed on the schedule provided, unless otherwise specified by the bidder. In consideration to the
expense of the Government in opening, tabulating, and evaluating this and other bids, and other considerations, the
undersigned agrees that this bid remain firm and irrevocable within one hundred twenty (120) calendar days from the date
opening to supply any or all of the items which prices are quoted.

NAME AND ADDRESS OF BIDDER:

SIGNATURE AND TITLE OF PERSON
AUTHORIZED TO SIGN THIS BID:

AWARD: CONTRACT NO.: _____ AMOUNT: _____ DATE: _____

ITEM NO(S). AWARDED: _____

CONTRACTING OFFICER:

JOHN M. BENAVENTE, P.E. DATE
Interim General Manager

NAME AND ADDRESS OF CONTRACTOR:

SIGNATURE AND TITLE OF PERSON

INVITATION FOR BID NO.: GPA-039-15
 Requisition No. 27650

NO.	DESCRIPTION	QTY.	U/I	U/P	T/P
-----	-------------	------	-----	-----	-----

1.0	450 kVAR Fixed Capacitor 450kVAR Fixed Shunt Pole Mounted Distribution Capacitor Bank, Factory Wired and Assembled in an Un-Grounded WYE, Configuration for use on a 13,800V Distribution System GPA Specification E-020, Revision 3	7	EA	\$ _____	\$ _____
-----	---------------------------------------------------------------------------------------------------------------------------------------------------------------------------------------------------------------------------------------------------	---	----	----------	----------

Note: This order is for Fixed and Not Switched Capacitor Banks

***** APPROVED EQUAL OR BETTER *****

NOTE:

Notwithstanding the fact that this contract was written by one (1) party, it will be construed that it was writtent by two (2) parties.

DELIVERY REQUIREMENT:

4-6 Weeks ARO

TO BE COMPLETED BY BIDDER:

MANUFACTURED BY: _____

BRAND NAME: _____

PLACE OF ORIGIN: _____

EXPORT ABROAD: _____

TIME OF DELIVERY AFTER RECEIPT OF PURCHASE ORDER: _____

**All deviations shall be identified
 REMARKS / DEVIATIONS:**

Specifications reviewed by:

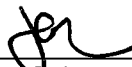
 5/8/15
 Joven C. Acosta, P.E. Date
 Engineering Manager

 5-6-15

INVITATION FOR BID NO.: GPA-039-15

Requisition No. 27650

NO.	DESCRIPTION	QTY.	U/I	U/P	TIP
2.0	900 kVAR Fixed Capacitor	6	EA	\$ _____	\$ _____

900kVAR Fixed Shunt Pole Mounted Distribution Capacitor Bank, Factory Wired and Assembled in an Un-Grounded WYE, Configuration for use on a 13,800V Distribution System
GPA Specification E-020, Revision 3

Note: This order is for FIXED and NOT Switched Capacitor Banks

***** APPROVED EQUAL OR BETTER *****

NOTE:

Notwithstanding the fact that this contract was written by one (1) party, it will be construed that it was writtent by two (2) parties.

DELIVERY REQUIREMENT:

4-6 Weeks ARO

TO BE COMPLETED BY BIDDER:

MANUFACTURED BY: _____

BRAND NAME: _____

PLACE OF ORIGIN: _____

EXPORT ABROAD: _____

TIME OF DELIVERY AFTER RECEIPT OF PURCHASE ORDER: _____

**All deviations shall be identified
 REMARKS / DEVIATIONS:**

Specifications reviewed by:

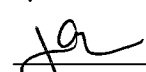
 5/8/15
 Joven G. Acosta, P.E. Date
 Engineering Manager

 5-6-15

 <p>GUAM POWER AUTHORITY AGANA, GUAM</p>	<p>SPECIFICATION No. E-020</p>	<p>REVISION: 3 December 16, 2010</p>
<p>PREPARED BY THE ENGINEERING DEPT.</p>		

GUAM POWER AUTHORITY
P.O. BOX 2977
AGANA, GUAM 96932

TRANSMISSION & DISTRIBUTION SPECIFICATION

SPECIFICATION NO. E-020

FOR

POLE MOUNTED DISTRIBUTION CAPACITORS

EFFECTIVE DATE: 12/20/10	ISSUED: 	APPROVED: 
--------------------------	---------------------------------------------------------------------------------------------	-------------------------------------------------------------------------------------------------

 <p>GUAM POWER AUTHORITY AGANA, GUAM</p> <p>PREPARED BY THE ENGINEERING DEPT.</p>	<p>SPECIFICATION No. E-020</p>	<p>PAGE 1 OF 14</p> <p>REVISION: 3 December 16, 2010</p>
------------------------------------------------------------------------------------------------------------------------------------------------------------------------	--------------------------------	--------------------------------------------------------------

POLE MOUNTED DISTRIBUTION CAPACITORS

TABLE OF CONTENTS

SECTION		PAGE
1.0	Scope	2
2.0	Applicable Publication.....	2
3.0	Deviations and Non-conformance Requirements	2
4.0	Submittals	2
5.0	Certified Laboratory Tests.....	3
6.0	Performance and Testing	4
7.0	Ratings.....	5
8.0	Design and Construction	5
9.0	Manufacturing.....	11
10.0	Quality Control	11
11.0	Packing and Shipping	11
	Capacitor Unit Data Sheet.....	13
	Figure A – Mounting Bracket.....	14

EFFECTIVE DATE: 12/20/10	ISSUED: 	APPROVED: 
--------------------------	---------------------------------------------------------------------------------------------	-------------------------------------------------------------------------------------------------

	<p>GUAM POWER AUTHORITY AGANA, GUAM</p>	<p>SPECIFICATION No. E-020</p>	<p>PAGE 2 OF 14 REVISION: 3 December 16, 2010</p>
<p>PREPARED BY THE ENGINEERING DEPT.</p>			

1.0 SCOPE

- 1.1 This specification covers the electrical characteristics and design features for pole mounted, shunt capacitor equipment, single-phase units rated 7,970 volts, 60 Hz factory wired and assembled in an ungrounded WYE configuration for use on a 13,800 volt distribution system.
- 1.2 The capacitor is intended for use in tropical weather conditions with a corrosive sea air atmosphere, with wind strength of 155 mph and subject to moderate and severe earthquakes.

2.0 APPLICABLE PUBLICATION

- 2.1 The equipment specified herein shall be designed, manufactured, assembled, and tested in accordance with ANSI C37.66, ANSI C55.1, and NEMA CP1 including the latest revisions with respect to material, design, and tests.

3.0 DEVIATIONS AND NON-CONFORMANCE REQUIREMENTS

- 3.1 Deviations from this specification or changes in the material or design after the purchase order has been placed must be approved by the GPA Engineering department and acknowledged by a Purchase Order Amendment issued by GPA.
- 3.2 Units received with deviations or non-conformance that are not acknowledged per Section 3.1 are subject to rejection. The Supplier of rejected units is responsible for any corrective action as specified by GPA including but not limited to materials, labor and transportation necessary to dispose of or make the units conform to the specification.
- 3.3 Notification of defective units discovered before or after installation that are believed to be inherent to manufacturing problems or workmanship shall be made and forwarded to the Supplier. The description of the item, documentation of the problem and the described information, disposition, and/or follow-up (as appropriate) that GPA expects from the Supplier will be specified. The Supplier's response shall be made within thirty (30) days unless an extension is acknowledged and approved in writing by the GPA Manager of Engineering.

4.0 SUBMITTALS

- 4.1 Shop drawings indicating details of construction and the outline of all connectors shall be submitted to GPA Engineering for review and approval.

Information required includes:

- a. Mounting dimensions
- b. Rack dimensions

EFFECTIVE DATE: 12/20/10	ISSUED: 	APPROVED: 
--------------------------	---------------------------------------------------------------------------------------------	-------------------------------------------------------------------------------------------------

 <p>GUAM POWER AUTHORITY AGANA, GUAM</p> <p>PREPARED BY THE ENGINEERING DEPT.</p>	<p>SPECIFICATION No. E-020</p>	<p>PAGE 3 OF 14</p> <p>REVISION: 3 December 16, 2010</p>
------------------------------------------------------------------------------------------------------------------------------------------------------------------------	--------------------------------	--------------------------------------------------------------

- c. Location of terminals
- d. Weights
- e. Nameplate
- f. Connection diagram

Drawings showing metric measurements shall also indicate the equivalent English measurement. These drawings shall be made a part of the quotation.

4.2 Supplementary Information

4.2.1 Probability of Rupture and Time-Current Curves

Two sets of Probability of Rupture and Time-Current Curves shall be provided on standard log-log graph paper (Keuffel & Esser Co. #495259 or equivalent).

4.2.2 Dielectric Materials and Instrument Transformers

Two sets of data for dielectric materials and for the instrument transformers shall be provided.

4.3 GPA shall be allowed two (2) weeks to review and approve drawings provided in Section 4.1 without affecting the shipping date. Delays in delivery due to drawings that are disapproved during this review period are the responsibility of the Supplier.

4.4 Drawings returned to the Supplier as approved shall be considered authorization to proceed with the work. The approval of GPA shall in no way abrogate the requirements of this specification.

4.5 Instruction books shall be furnished which shall contain the description of components, parts and accessories, detailed installation instructions, complete instructions covering operation and maintenance of equipment and a complete replacement parts list.

4.6 At least three (3) complete sets of drawings and instructions manuals shall be provided to GPA's Engineering Department prior to delivery.

5.0 CERTIFIED LABORATORY TEST REPORTS

Certified tests shall be conducted in accordance with applicable standards and as listed in 6.0. The Supplier shall furnish two (2) copies of certified test reports for all tests to the GPA Manager of Engineering within two (2) weeks prior to delivery. This information shall include, but is not limited to the following:

5.1 Loss versus temperature curve between 40°C to 100°C.

EFFECTIVE DATE: 12/16/10	ISSUED: 	APPROVED: 
--------------------------	---------------------------------------------------------------------------------------------	-------------------------------------------------------------------------------------------------

 <p>GUAM POWER AUTHORITY AGANA, GUAM</p>	<p>SPECIFICATION No. E-020</p>	<p>PAGE 4 OF 14 REVISION: 3 December 16, 2010</p>
<p>PREPARED BY THE ENGINEERING DEPT.</p>		

- 5.2 Loss versus time at 40°C curve between zero to 4000 hours, or to the point where the losses are constant.
- 5.3 Capacitance versus temperature curve between 40°C to 100°C.
- 5.4 Corona start and extinction voltage versus temperature curves between 40°C to 100°C.
- 5.5 Maximum temperature rise versus hours energized as per the thermal stability test.
- 5.6 Detailed design information (See attached Capacitor Unit Data Sheet).

6.0 PERFORMANCE AND TESTING

Capacitor units shall meet the performance and testing requirements specified in ANSI C55.1 (paragraphs 6.2 through 6.12) and NEMA CP1 (paragraphs 5.05 through 5.14) including the latest revisions with respect to material, design and tests unless otherwise specified below.

6.1 Dielectric Strength Test

The dielectric stress shall be such as to assure long capacitor life and high reliability. The maximum annual failure rate shall not exceed 0.5% during the first 1-1/2 years of energization.

6.2 Impulse Withstand Test

6.3 Thermal Stability Test

The temperature of the hottest spot inside the capacitor case shall not exceed 95°C when the capacitor is operated continuously at 110% of the rated voltage in a 40°C draft-free ambient environment.

6.4 Radio Influence Voltage Test



6.5 Voltage Decay Test

6.6 Case Rupture Test

6.7 Short-Time Overvoltage Test

6.8 Capacitance Test

6.9 Loss Test

EFFECTIVE DATE: 12/16/10	ISSUED: 	APPROVED: 
--------------------------	---------------------------------------------------------------------------------------------	-------------------------------------------------------------------------------------------------

	<p>GUAM POWER AUTHORITY AGANA, GUAM</p>	<p>SPECIFICATION No. E-020</p>	<p>PAGE 5 OF 14 REVISION: 3 December 16, 2010</p>
<p>PREPARED BY THE ENGINEERING DEPT.</p>			

6.9.1 Acceptance statistical sampling methods may be used for this test if desired.

6.9.2 A plot of the capacitor losses at rated voltage and frequency at an ambient temperature of 40°C shall be made between zero and 4000 hours or to the point where losses are constant.

6.10 Discharge Resistor Test

6.11 Leak Test

6.12 Corona Starting Voltage

The internal corona starting voltage or ionization level shall not be less than 150% of rated voltage at 25°C. This requirement shall be met as follows:

6.12.1 The dissipation factor of the test specimen shall be measured and recorded with the dielectric temperature at 100°C.

6.12.2 After the dielectric temperature of the test specimen has returned to 25°C, the test specimen shall be placed in 25°C ambient temperature and alternately energized for five minutes at 150% voltage and de-energized for 25 minutes, a total of 60 times.

6.12.3 After completion of the test, the dissipation factor of the test specimen shall again be measured with its dielectric temperature at 100°C and recorded. This reading shall be made as soon as practicable and, in any case, not longer than 72 hours after completion of the energized test.

6.12.4 The final dissipation factor reading shall not exceed the initial reading by more than 10%.

6.12.5 Acceptable statistical sampling methods may be used for this test if desired.

7.0 RATINGS

Standard KVAR and voltage ratings for the capacitor units furnished individually or as part of factory assembled capacitor equipment are as follows:

<u>Single Phase KVAR</u>	<u>Voltage (V)</u>
150	7970
200	7970

8.0 DESIGN AND CONSTRUCTION

EFFECTIVE DATE: 12/10/10	ISSUED: [Signature]	APPROVED: [Signature]
--------------------------	---------------------	-----------------------

 <p>GUAM POWER AUTHORITY AGANA, GUAM</p>	<p>SPECIFICATION No. E-020</p>	<p>PAGE 6 OF 14 REVISION: 3 December 16, 2010</p>
<p>PREPARED BY THE ENGINEERING DEPT.</p>		

8.1 Capacitor Banks

- 8.1.1 Capacitor banks shall consist of 3, 6, or 9 each 150 KVAR or 200 KVAR single-phase, fixed units as specified in the Purchase Order.
- 8.1.2 The capacitor-equipped, pole-mounted racks shall have sufficient strength such that, when mounted on the pole, they are capable of sustaining the application of a 200 pound load (with a safety factor of 2) at one end of the length-wise dimension of the rack without breaking or deforming. The opposite end shall also be capable of sustaining this load. The loads will not be applied simultaneously.
- 8.1.3 All pole-mounted capacitor banks shall be equipped with provisions for mounting lightning arrestors, capacitor switches, potential transformer and a junction box.
- 8.1.4 When required, a switched capacitor bank shall be provided with a surface-mounted control unit.

8.2 Capacitor Bank Wiring

- 8.2.1 Bank wiring shall be arranged so that neutral wiring is closest to the pole surface. Neutral wiring shall clear the surface of the pole by 6 inches.
- 8.2.2 All capacitor banks shall be wired for operation on a 13.8 kV system, with a floating neutral.
- 8.2.3 Wires connecting capacitor units and bushing terminals shall be bird-proof using covered wires and terminal caps.
 - 8.2.3.1 The bird proofing shall be made of material that is not subject to ultra-violet degradation.
 - 8.2.3.2 The bird proofing shall be light gray in color conforming to ANSI No. 70 (Munsell 5 BG 7.0/0.4).
- 8.2.4 The capacitor rack grounding provision shall not be bird-proof.

8.3 Capacitor Racks

- 8.3.1 Capacitor racks shall be welded, structural aluminum. All welds shall be full penetration.
- 8.3.2 Each rack shall be furnished with a connector for positive electrical grounding.

EFFECTIVE DATE: 12/16/10	ISSUED: 	APPROVED: 
--------------------------	---------------------------------------------------------------------------------------------	-------------------------------------------------------------------------------------------------



GUAM POWER AUTHORITY
AGANA, GUAM

SPECIFICATION No. E-020

PAGE 7 OF 14

REVISION: 3
December 16, 2010

PREPARED BY THE ENGINEERING DEPT.

- 8.3.3 Each rack shall have four 1-1/2" diameter, aluminum lifting eyes positioned for balanced lifting. Each eye shall be welded to the rack and shall be free from sharp edges.
- 8.3.4 Each rack shall have provisions to accept 150 or 200 KVAR capacitor tanks.
- 8.3.5 Each rack shall be furnished with the exact number of tanks as stated in the Purchase Order.
- 8.3.6 Each rack shall be free of fractures, cracking, or other imperfections.
- 8.3.7 Each rack shall have provisions to mount 3 single-phase capacitor switches, a potential transformer, and a junction box.
- 8.3.8 All the capacitor units, capacitor switches, potential transformers and junction box shall be pre-wired in the factory per the bank configuration. All the intra-rack connections shall be insulated and all live terminals shall be shielded by the insulation caps.
- 8.4 Mounting Brackets
- 8.4.1 Pole mounting brackets shall be welded, structural aluminum designed to reduce sway.
- 8.4.2 Brackets shall be designed to mount onto round concrete poles with diameters between 8 and 22 inches.
- 8.4.3 Mounting brackets shall have 11/16" holes to allow installation on pre-drilled concrete poles with a vertical, center to center mounting distance of 20 to 24 inches. The upper hole provision shall be fixed. The lower mounting provision shall be slotted 11/16 inch wide by 4 inches long. See Figure A for details.
- 8.5 Capacitor Unit Tanks
- 8.5.1 Standard tank material shall be made of 300 or 400 series stainless steel and resistant to a severely corrosive environment.
- 8.5.2 The tank, including the bushing seals, shall ensure that the capacitor will remain hermetically sealed throughout the life of the unit.
- 8.5.3 Outside Finish
- Each tank shall be coated with zinc chromate primer and the finish shall be a light gray color conforming to ANSI No. 70 (Munsell 5BG 7.0/0.4). The total external dry-film thickness of the paint shall be 3.5 mils minimum or equivalent protection as approved.

EFFECTIVE DATE:

12/16/10

ISSUED:

1/5/11

APPROVED:

[Signature]

 <p>GUAM POWER AUTHORITY AGANA, GUAM</p>	<p>SPECIFICATION No. E-020</p>	<p>PAGE 8 OF 14 REVISION: 3 December 16, 2010</p>
<p>PREPARED BY THE ENGINEERING DEPT.</p>		

8.6 Capacitor Unit Dielectric Materials

8.6.1 The dielectric system shall consist of a solid insulation of synthetic film impregnated with a stable and PCB free dielectric fluid to provide high reliability and long life and is environmentally acceptable. A dielectric consisting of a synthetic film and paper combination may be accepted as an alternate.

8.7 Capacitor Unit Bushings and Terminals

8.7.1 Two bushings shall be furnished with each capacitor unit. Bushings shall be made of glazed, wet-processed porcelain.

8.7.2 Porcelain bushing glaze shall be light gray in color conforming to ANSI 70 (Munsell 5 BG 7.0/0.4).

8.7.3 All leads shall be brought out through bushings with full electrical rating.

8.7.4 The bushing minimum creepage distance shall be 17 inches.

8.7.5 The minimum strike distance between phases shall be 6 ½ inches.

8.7.6 Bushing terminals shall be tin plated copper or bronze parallel groove type suitable for a minimum range of conductor sizes from No. 8 solid to and including No. 2 stranded copper.

8.7.7 Bushing seals shall have adequate mechanical strength and flexibility to withstand reasonable cantilever movement or impact without damage.

8.8 Switched Capacitor Control Unit

For orders requiring the use of switched capacitors, the following requirements must be followed:

8.8.1 Stand-alone VAR Sensing Capacitor Bank Controller units must be included in the purchase order.

8.8.2 Controller units shall have local control actions based on VAR, temperature, neutral current, line voltage, and time of day. The units shall be capable of operating with any combination of local control actions.

EFFECTIVE DATE: 12/16/10	ISSUED: 	APPROVED: 
--------------------------	---------------------------------------------------------------------------------------------	-------------------------------------------------------------------------------------------------



GUAM POWER AUTHORITY
AGANA, GUAM

SPECIFICATION No. E-020

PAGE 9 OF 14

REVISION: 3
December 16, 2010

PREPARED BY THE ENGINEERING DEPT.

8.8.3 Control units shall provide data logging of line voltage, watts, and kVAR including the before and after operating voltage, kVAR and power factor direction. High and low voltage and adaptive (delta) voltage shall be available via the front panel user interface or a DNP point. The delta voltage can be calculated using the before and after operating voltage indicated in the data log.

8.8.4 Control units shall be fitted with status/data LED indicators.

8.8.5 Control unit enclosures shall be surface mounted, NEMA 4R, with utility seal and padlocking provisions.

8.9 Capacitor switch

8.9.1 The capacitor switch shall be a single phase, electrically operated vacuum switch with close and latch capability. The switch shall be rated for up to 14.4 kV ungrounded WYE systems

8.9.2 Rating

Maximum Design Voltage, kV	15.0
Nominal Operation Voltage, kV	14.4
Basic Insulation Level (BIL), kV	95
60 Hz Withstand Voltage, kV	
Dry, One Minute	50
Wet, Ten Minute	45
Continuous Current Rating, Amps	200
Load Interrupting Ability (Inductive), Amps	200
10-100% power factor	
Maximum capacitive current, Amps	200
Rated Asymmetrical Making Current, Amps	9000
Short Time Current, Amps	
Asymmetric (10) cycle	9000
Symmetric (1/2 second)	6000
Symmetric (1 second)	4500
Rated High Frequency Peak	
Transient Making Current, Amps	12000
Rated Transient Inrush Frequency, Hz	6000

EFFECTIVE DATE:

12/16/10

ISSUED:

1-2

APPROVED:

[Signature]

 <p>GUAM POWER AUTHORITY AGANA, GUAM</p>	<p>SPECIFICATION No. E-020</p>	<p>PAGE 10 OF 14 REVISION: 3 December 16, 2010</p>
<p>PREPARED BY THE ENGINEERING DEPT.</p>		

8.9.3 Duty Cycle

200 Amps	400 operations
100 Amps	400 operations
50 Amps	400 operations

8.9.4 The switch shall be equipped with vacuum interruption and the vacuum bottle shall be encapsulated in the solid polymer. The solid polymer shall have high surface tracking resistance and can withstand Ultra – Violet exposure without degradation.

8.9.5 Fluorocarbons shall not be used in the manufacturing of the switch.

8.9.6 There shall be no porcelain used on the external portion of the switch. The switch shall not chip, crack or shatter.

8.9.7 A manual operating handle shall be provided as standard with load break opening and closing capabilities. The manual operating handle may also be used for closing into fault currents up to the rated making current.

8.9.8 The switch shall be operable in any mounting orientation.

8.9.9 Electrical operations shall be accomplished utilizing a motor which charges a spring to open and close the contacts. The current requirement for opening or closing shall not exceed 3 Amps

8.9.10 The switch shall withstand a minimum of 30,000 mechanical operations. An operation is defined as an open and close cycle.

8.10 Potential Transformer

8.10.1 A potential transformer shall be supplied as required for operating the switches and the controller

8.10.2 The potential transformer shall be of oil type, single phase.

8.10.3 The potential transformer shall be mounted on the rack with the switches.

8.11 Current Sensor

8.11.1 A current sensor shall provide current readings to the controller.

8.11.2 The current sensor shall be compatible with the controller and designed for outdoor use.

EFFECTIVE DATE: 12/16/10

ISSUED: 

APPROVED: 

 <p>GUAM POWER AUTHORITY AGANA, GUAM</p>	<p>SPECIFICATION No. E-020</p>	<p>PAGE 11 OF 14 REVISION: 3 December 16, 2010</p>
<p>PREPARED BY THE ENGINEERING DEPT.</p>		

8.12 Junction Box

8.12.1 A junction box and terminal shall be provided for connecting controllers, the potential transformer, and switches.

8.12.2 The junction box shall be made of stainless steel and sealed and suitable for outdoor application.

8.12.3 The terminal blocks shall be made of heavy duty grade suitable for outdoor use.

9.0 MANUFACTURING

9.1 Nameplate

Each capacitor shall have a nameplate made of 300 or 400 stainless steel. The information shown on the nameplate shall be as specified in NEMA Publication No. CP1 and ANSI Standard C55.1. Each capacitor rack nameplate shall have all required information plus the weight of the complete assembly.

9.2 Non-PCB Indicator

A weather-resistant label or decal shall be located on each end of each capacitor rack or tank to signify biodegradable dielectric fluid.

10.0 QUALITY CONTROL

10.1 The Supplier shall have a quality control program to ensure compliance with the requirements of this specification. The program shall be documented and available for GPA's review if requested.

10.2 Documentation of the quality control program shall indicate where in the production and manufacturing process the quality checks are taken, describe the purpose of the checks, and describe the nature of the check, i.e. if check is visual only or if electrical or mechanical testing is used.

10.3 The supplier shall certify that the compositions of all materials used are sufficient to meet the requirements of this specification.

11.0 PACKING AND SHIPPING

EFFECTIVE DATE: 12/16/10	ISSUED: 	APPROVED: 
--------------------------	---------------------------------------------------------------------------------------------	-------------------------------------------------------------------------------------------------

 <p>GUAM POWER AUTHORITY AGANA, GUAM</p>	<p>SPECIFICATION No. E-020</p>	<p>PAGE 12 OF 14</p> <p>REVISION: 3 December 16, 2010</p>
<p>PREPARED BY THE ENGINEERING DEPT.</p>		

- 11.1 The Supplier shall have adequate work and inspection instructions for handling, interim storage, preservation, packaging, and shipping to protect the quality of the capacitor and prevent damage, loss and deterioration.
- 11.2 The capacitor rack equipment shall be shipped in an open type vehicle to facilitate unloading by use of a forklift.
- 11.3 The capacitor shall be securely blocked to prevent shifting during transit.

EFFECTIVE DATE: 12/16/10	ISSUED: <i>[Signature]</i>	APPROVED: <i>[Signature]</i>
--------------------------	----------------------------	------------------------------

	<p style="text-align: center;">GUAM POWER AUTHORITY AGANA, GUAM</p>	<p style="text-align: center;">SPECIFICATION No. E-020</p>	<p>PAGE 13 OF 14</p> <p>REVISION: 3 December 16, 2010</p>
<p>PREPARED BY THE ENGINEERING DEPT.</p>			

CAPACITOR UNIT DATA SHEET

1. Catalog Number _____
2. Capacitor Unit Drawing Number _____
3. Volts _____ KVAR _____ No. of Phases _____
4. Weight Per Unit _____
5. Impulse (BIL), kV _____
6. Case Material _____ Finish _____ Color _____
7. Bushing Color _____
8. Impregnating
Liquid _____
9. Foil _____
10. Dielectric Thickness:
 - a. Paper: No. of Sheets _____ Thickness of each: _____ Mils
 - b. Film: No. of Sheets _____ Thickness of each: _____ Mils
 - c. Total Dielectric Thickness: _____ Mils
11. Dielectric Thickness:
 - a. Paper: _____ V/Mil
 - b. Film: _____ V/Mil
12. Corona start and extinction voltage versus Dielectric temperature obtained from actual test.
See Curve _____
 - a. Inception Voltage at 25°C, _____ % Rated Voltage
 - b. Inception Voltage at -25°C, _____ % Rated Voltage
 - c. Minimum Inception Voltage throughout _____ % of Rated Voltage Temperature range.
13. Volts per section at rated voltage: _____
14. Case rupture curve: _____
15. Capacitor Make-up: Series Sections: _____ Parallel Sections: _____
16. Maximum temperature rise per Stability Test NEMA CP1-5.07 (ambient temperature of 45°C)
 - a. Internal Hot Spot, °C _____ See Curve _____
 - b. Internal Hot Spot, °C _____ See Curve _____
17. Dielectric Loss Watts:
 - a. Dielectric Loss Watts/KVAR (avg.) _____ at 40°C
 - b. Dielectric Loss Watts/KVAR (max.) _____ at 40°C
 - c. Dielectric Loss Watts/KVAR (min.) _____ at 40°C

EFFECTIVE DATE: 12/10/10	ISSUED: [Signature]	APPROVED: [Signature]
--------------------------	---------------------	-----------------------



GUAM POWER AUTHORITY
AGANA, GUAM

SPECIFICATION No. E-020

PAGE 14 OF 14

REVISION: 3
December 16, 2010

PREPARED BY THE ENGINEERING DEPT.

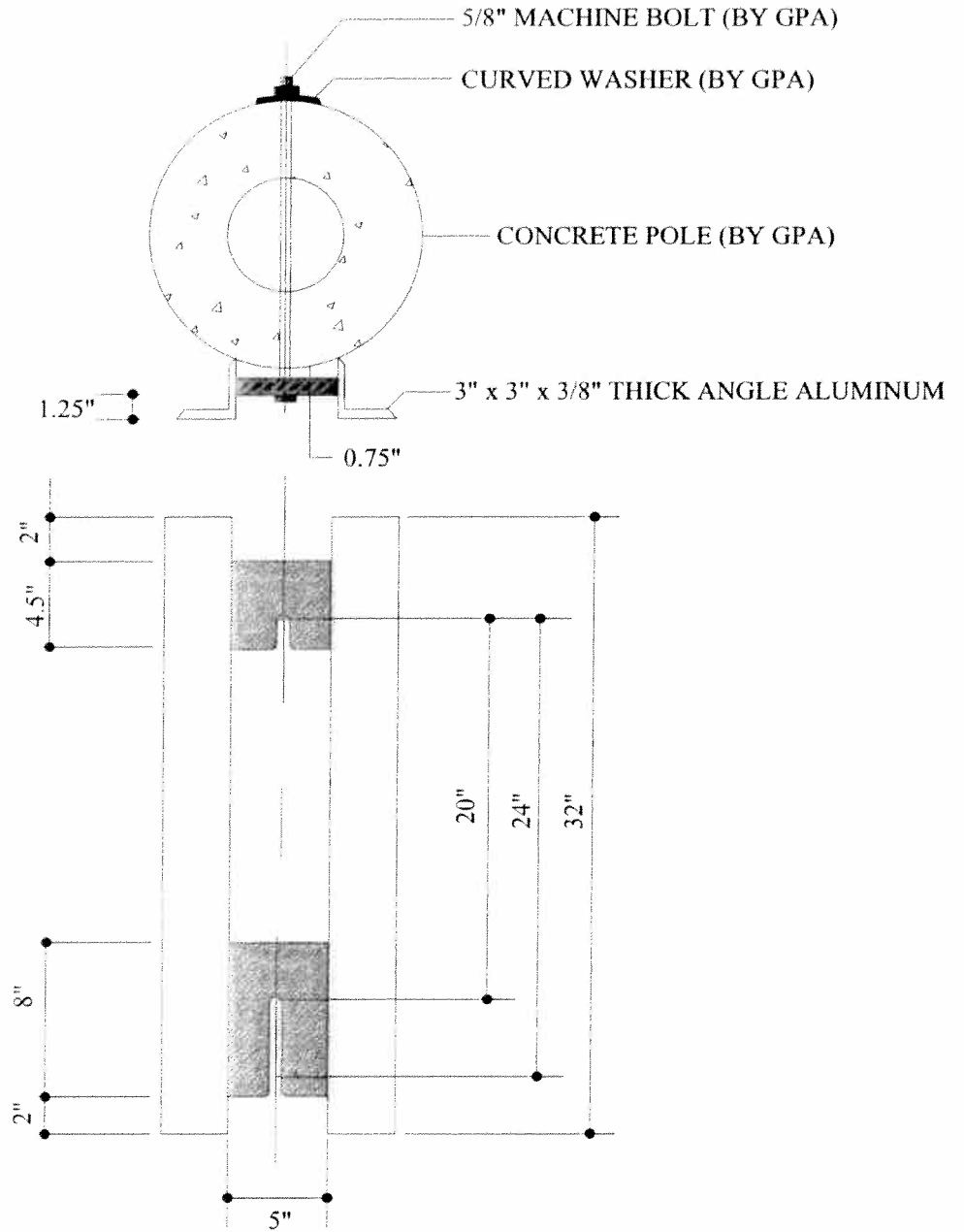

Figure A
Mounting Bracket

EFFECTIVE DATE: 2/10/10

ISSUED: [Signature]

APPROVED: [Signature]



GUAM POWER AUTHORITY

ATURIDÄT ILEKTRESEDÄT GUAHAN
P.O.BOX 2977 • AGANA, GUAM U.S.A. 96932-2977

Edward J.B. Calvo
Governor

Telephone Nos. (671) 648-3054/55 Fax: 648-3165

Raymond S. Tenorio
Lieutenant Governor

BID BOND

NO.: _____

KNOW ALL MEN BY THESE PRESENTS that _____, as

Principal Hereinafter called the Principal, and (Bonding Company), _____
A duly admitted insurer under the laws of the Territory of Guam, as Surety, hereinafter called the Surety are
Held firmly bound unto the Territory of Guam for the sum of _____ Dollars
(\$_____), for Payment of which sum will and truly to be made, the said Principal and the said
Surety bind ourselves, our heirs, executors, administrators, successors and assigns, jointly and severally, firmly
by these presents.

WHEREAS, the Principal has submitted a bid for (identify project by number and brief description)

NOW, THEREFORE, if the Territory of Guam shall accept the bid of the Principal and the Principal shall
enter into a Contract with the Territory of Guam in accordance with the terms of such bid, and give such bond or
bonds as may be specified in bidding or Contract documents with good and sufficient surety for the faithful
performance of such Contract Documents with good and sufficient surety for the faithful performance of such
Contract and for the prompt payment of labor and material furnished in the prosecution thereof, or in the event
of the failure of the Principal to enter such Contract and give such bond or bonds, if the Principal shall pay to the
Territory of Guam the difference not to exceed the penalty hereof between the amounts specified in said bid
and such larger amount for which the Territory of Guam may in good faith contract with another party to perform
work covered by said bid or an appropriate liquidated amount as specified in the Invitation for Bids then this
obligation shall be null and void, otherwise to remain full force and effect.

Signed and sealed this _____ day of _____ 2015.

(PRINCIPAL) (SEAL)

(WITNESS)

(TITLE)

(MAJOR OFFICER OF SURETY)

(TITLE)

(TITLE)

(RESIDENT GENERAL AGENT)

SEE INSTRUCTIONS FOR SUPPORTING DOCUMENTS REQUIRED.

INSTRUCTION TO PROVIDERS:

NOTICE to all Insurance and Bonding Institutions:

The Bond requires the signatures of the Vendor, two (2) major Officers of the Surety and Resident General Agent, if the Surety is a foreign or alien surety.

When the form is submitted to the Guam Power Authority, it should be accompanied with copies of the following:

1. Current Certificate of Authority to do business on Guam issued by the Department of Revenue and Taxation.
2. Power of Attorney issued by the Surety to the Resident General Agent.
3. Power of Attorney issued by two (2) major officers of the Surety to whoever is signing on their behalf.

Bonds, submitted as Bid Guarantee, without signatures and supporting documents are invalid and Bids will be rejected.



GUAM POWER AUTHORITY

ATURIDAT ILEKTRESEDAT GUAHAN
P O BOX 2977, AGANA, GUAM 96932-2977

SPECIAL PROVISION FOR MAJOR SHAREHOLDERS DISCLOSURE AFFIDAVIT

All Bidders/Offerors are required to submit a current affidavit as required below. Failure to do so will mean disqualification and rejection of the bid/rfp.

5 GCA §5233 (Title 5, Section 5233) states:

"Section 5233 Disclosure of Major Shareholders. As a condition of submitting a bid or offer, any partnership, sole proprietorship or corporation doing business with the government of Guam shall submit an affidavit executed under oath that lists the name and address of any person who has held more than ten percent (10%) of the outstanding interest or shares in said partnership, sole proprietorship or corporation at any time during the twelve (12) month period immediately preceding submission of a bid, or, that it is a not for profit organization that qualifies for tax exemption under the Internal Revenue Code of the United States or the Business Privilege Tax law of Guam, Title 12, Guam Code Annotated, Section 26203[©]. With the exception of not for profit organizations, the affidavit shall contain the number of shares or the percentage of all assets of such partnership, sole proprietorship or corporation which have held by each such person during the twelve (12) month period. In addition, the affidavit shall contain the name and address of any person who has received or is entitled to receive a commission, gratuity or other compensation for procuring or assisting in obtaining business related to the bid or offer and shall also contain the amounts of any such commission, gratuity or other compensation. The affidavit shall be open and available to the public for inspection and copying."

1. If the affidavit is a copy, indicate the BID/RFP number and where it is filed.
2. Affidavits must be signed within 60 days of the date the bids or proposals are due.

MAJOR SHAREHOLDERS OF DISCLOSURE AFFIDAVIT

TERRITORY OF GUAM)

HAGATNA, GUAM)

I, undersign, _____,

(partner or officer of the company of, etc.)

being first duly sworn, deposes and says:

1. That the person who have held more than ten percent (10%) of the company's shares during the past twelve (12) months are as follows:

<u>Name</u>	<u>Address</u>	<u>Percentage of Shares Held</u>
_____	_____	_____
_____	_____	_____
_____	_____	_____
_____	_____	_____
Total number of shares		_____

2. Persons who have received or are entitled a commission, gratuity or other compensation for procuring or assisting in obtaining business related to the bid/rfp for which this Affidavit is submitted are as follows:

<u>Name</u>	<u>Address</u>	<u>Amount of Commission Gratuity or other Compensation</u>
_____	_____	_____
_____	_____	_____

Further, affiant sayeth naught.

Date: _____

 Signature of individual if bidder/offeror is a sole Proprietorship; Partner, if the bidder/offeror is a Partnership Officer, if the bidder/offeror is a corporation.

Subscribe and sworn to before me this _____ day of _____, 20_____.

Notary Public _____

In and for the Territory of Guam

My Commision expires _____.

NON-COLLUSION AFFIDAVIT

Guam)
)ss:
Hagatna)

I, _____ first being duly sworn, depose and say:
(Name of Declarant)

1. That I am the _____ of _____.
(Title) (Name of Bidding/RFP Company)
2. That in making the foregoing proposal or bid, that such proposal or bid is Genuine and not collusive or shame, that said bidder/offeror has not colluded, Conspired, connived or agreed, directly or indirectly, with any bidder or person, to put in a sham or to refrain from bidding or submitting a proposal and has not in any manner, directly or indirectly, sought by agreement or collusion, or communication or conference, with any person, to fix the bid of affiant or any other bidder, or to secure any overhead, project or cost element of said bid price, or of that of any bidder, or to secure any advantage against the GUAM POWER AUTHORITY or any person interested in the proposed contract; and
3. That all statements in said proposal or bid are true.
4. This affidavit is made in compliance with Guam Administrative Rules and Regulations §§3126(b).

(Declarant)

SUBSCRIBED AND SWORN to me before this _____ day of _____, 2015.

)Seal(

Notary Public

NO GRATUITIES OR KICKBACKS AFFIDAVIT

AFFIDAVIT

(Offeror)

TERRITORY OF GUAM)

)

SS:

HAGATNA, GUAM)

)

_____, being first duly sworn, deposes and says:

As the duly authorized representative of the Offeror, that neither I nor of the Offeror's officers, representatives, agents, subcontractors, or employees has or have offered, given or agreed to give any government of Guam employee or former employee, any payment, gift, kickback, gratuity or offer of employment in connection with Offeror's proposal.

Signature of Individual if Proposer is a Sole Proprietorship;

Partner, if the Proposer is a Partnership;

Officer, if the Proposer is a Corporation

SUBSCRIBED AND SWORN to before me this ____ day of _____, 2015.

Notary Public
In and for the Territory of Guam
My Commission Expires:

ETHICAL STANDARDS AFFIDAVIT

AFFIDAVIT

(Proposer)

TERRITORY OF GUAM)

)

SS:

HAGATNA, GUAM)

)

_____, being first duly sworn, deposes and says:

That I am (the Sole Proprietor, a Partner or Officer of the Offeror)

That Offeror making the foregoing Proposal, that neither he or nor of the Offeror's officers, representatives, agents, subcontractors, or employees of the Offeror have knowingly influenced any government of Guam employee to breach any of the ethical standards set forth in 5 GCA Chapter 5 Article 11, and promises that neither he nor any officer, representative, agent, subcontractor, or employee of Offeror will knowingly influence any government of Guam employee to breach any ethical standard set for in 5 GCA Chapter 5 Article 11.

Signature of Individual if Proposer is a Sole Proprietorship;
Partner, if the Proposer is a Partnership;
Officer, if the Proposer is a Corporation

SUBSCRIBED AND SWORN to before me this ____day of _____, 2015.

Notary Public
In and for the Territory of Guam
My Commission Expires:

DECLARATION RE-COMPLIANCE WITH U.S. DOL WAGE DETERMINATION

Procurement No.: _____

Name of Offeror Company: _____

_____ hereby certifies under penalty of perjury:

(1) That I am _____ (the offeror, a partner of the offeror, an officer of the offeror) making the bid or proposal in the foregoing identified procurement;

(2) That I have read and understand the provisions of 5 GCA § 5801 and § 5802 which read:

§ 5801. Wage Determination Established.

In such cases where the government of Guam enters into contractual arrangements with a sole proprietorship, a partnership or a corporation ('contractor') for the provision of a service to the government of Guam, and in such cases where the contractor employs a person(s) whose purpose, in whole or in part, is the direct delivery of service contracted by the government of Guam, then the contractor shall pay such employee(s) in accordance with the Wage Determination for Guam and the Northern Mariana Islands issued and promulgated by the U.S. Department of Labor for such labor as is employed in the direct delivery of contract deliverables to the government of Guam.

The Wage Determination most recently issued by the U.S. Department of Labor at the time a contract is awarded to a contractor by the government of Guam shall be used to determine wages, which shall be paid to employees pursuant to this Article. Should any contract contain a renewal clause, then at the time of renewal adjustments, there shall be made stipulations contained in that contract for applying the Wage Determination, as required by this Article, so that the Wage Determination promulgated by the U.S. Department of Labor on a date most recent to the renewal date shall apply.

§ 5802. Benefits.

In addition to the Wage Determination detailed in this Article, any contract to which this Article applies shall also contain provisions mandating health and similar benefits for employees covered by this Article, such benefits having a minimum value as detailed in the Wage Determination issued and promulgated by the U.S. Department of Labor, and shall contain provisions guaranteeing a minimum of ten (10) paid holidays per annum per employee.

(3) That the offeror is in full compliance with 5 GCA § 5801 and § 5802, as may be applicable to the procurement referenced herein;

Signature of Individual if Proposer is a Sole Proprietorship;
Partner, if the Proposer is a Partnership;
Officer, if the Proposer is a Corporation

SUBSCRIBED AND SWORN to before me this ____ day of _____, 2015.

Notary Public
In and for the Territory of Guam
My Commission Expires:



GUAM POWER AUTHORITY

ATURIDAT ILEKTRESEDAT GUAHAN
P O BOX 2977, AGANA, GUAM 96932-2977

SPECIAL PROVISIONS

Restriction against Sex Offenders Employed by Service Providers to Government of Guam from Working on Government of Guam Property

GCA 5 §5253(b) restricts the OFFEROR against employing convicted sex offenders from working at Government of Guam venues. It states:

(b) All contracts for services to agencies listed herein shall include the following provisions: (1) warranties that no person providing services on behalf of the contractor has been convicted of a sex offense under the provisions of Chapter 25 of Title 9 GCA or an offense as defined in Article 2 of Chapter 28, Title 9 GCA, or an offense in another jurisdiction with, at a minimum, the same elements as such offenses, or who is listed on the Sex Offender Registry; and (2) that if any person providing services on behalf of the contractor is convicted of a sex offense under the provisions of Chapter 25 of Title 9 GCA or an offense as defined in Article 2 of Chapter 28, Title 9 GCA or an offense in another jurisdiction with, at a minimum, the same elements as such offenses, or who is listed on the Sex Offender Registry, that such person will be immediately removed from working at said agency and that the administrator of said agency be informed of such within twenty-four (24) hours of such conviction.

Signature of Bidder Date

Proposer, if an individual;
Partner, if a partnership;
Officer, if a corporation.

Subscribed and sworn before me this _____ day of _____, 2015.

Notary Public



GUAM POWER AUTHORITY

ATURIDÁT ILEKTRESEDÁT GUAHAN
P.O.BOX 2977 • AGANA, GUAM U.S.A. 96932-2977

Edward J.B. Calvo
Governor

Telephone Nos. (671) 648-3054/55 Fax: 648-3165

Raymond S. Tenorio
Lieutenant Governor

Accountability · Impartiality · Competence · Openness · Value

LOCAL PROCUREMENT PREFERENCE APPLICATION

Based on the law stipulated below, please place a checkmark or an "X" on the block indicating the item that applies to your business:

5GCA, Chapter 5, Section 5008, "Policy in Favor of Local Procurement" of the Guam Procurement Law states:

All procurement of supplies and services shall be made from among businesses licensed to do business on Guam and that maintains an office or other facility on Guam, whenever a business that is willing to be a contractor is:

- () (a) A licensed bonafide manufacturing business that adds at least twenty-five percent (25%) of the value of an item, not to include administrative overhead, suing workers who are U.S. Citizens or lawfully admitted permanent residents or nationals of the United States, or persons who are lawfully admitted to the United States to work, based on their former citizenship in the Trust Territory for the Pacific Islands; or
- () (b) A business that regularly carries an inventory for regular immediate sale of at least fifty percent (50%) of the items of supplies to be procured; or
- () (c) A business that has a bonafide retail or wholesale business location that regularly carries an inventory on Guam of a value of at least one half of the value of the bid or One Hundred Fifty Thousand Dollars (\$150,000.0) whichever is less, of supplies and items of a similar nature to those being sought; or
- () *(d) A service actually in business, doing a substantial business on Guam, and hiring at least 95% U.S. Citizens, lawfully admitted permanent residents or national of the Unites States, or persons who lawfully admitted to the United States to work, based on their citizenship in any of the nations previously comprising the Trust Territory of the Pacific Islands.

- Bidders indicating qualification under (d) may be considered QUALIFIED for the Local Procurement Preference **only if** the Government's requirement is for service. Service is defined Pursuant to 5 GCA Government Operations Subparagraph 5030 entitled DEFINITIONS under Chapter 5 of the Guam Procurement Law.

1. I _____, representative for _____, have read the requirements of the law cited above and do hereby qualify and elect to be given the LOCAL PROCUREMENT PREFERENCE for Bid No.: GPA _____. By filling in this information and placing my signature below, I understand that the Guam Power Authority will review this application and provide me with a determination whether or not the 15% preference will be applied to this bid.
2. I _____, representative for _____, have read the requirements of the law cited above, and do not wish to apply for the Local Procurement Preference for Bid No.: GPA _____.

Bidder Representative Signature

Date

NOTE:

Prospective Bidders not completing this form will automatically be not considered for Local Procurement Preference. Non-completion of this form is not a basis for rejection of the bid or proposal.

GOVERNMENT OF GUAM

GENERAL TERMS AND CONDITIONS

SEALED BID SOLICITATION AND AWARD

Only those Boxes checked below are applicable to this bid.

- [X] 1. **AUTHORITY:** This solicitation is issued subject to all the provision of the Guam Procurement Act (5GCA, Chapter 5) And the Guam Procurement Regulations (copies of both are available at the Office of the Complier of laws, Department of Law, copies available for inspection at the Guam Power Authority). It requires all parties involved in the Preparation, negotiation, performance, or administration of contracts to act in good faith.
- [X] 2. **GENERAL INTENTION:** Unless otherwise specified, it is the declared and acknowledged intention and meaning of these General Terms and conditions for the bidder to provide the Government of Guam (Government) with specified services or with materials, supplies or equipment completely assembled and ready for use.
- [X] 3. **TAXES:** Bidders are cautioned that they are subject to Guam Income Taxes as well as all other taxes on Guam Transactions. Specific information on taxes may be obtained from the Director of Revenue and Taxation.
- [X] 4. **LICENSING:** Bidders are cautioned that the Government will not consider for award any offer submitted by a bidder who has not complied with the Guam Licensing Law. Specific information on licenses may be obtained from the Director of Revenue and Taxation.
- [X] 5. **LOCAL PROCUREMENT PREFERENCE:** All procurement of supplies and services where possible, will be made from among businesses licensed to do business on Guam in accordance with section 5008 of the Guam Procurement Act (5GCA, Chapter 5) and Section 1-104 of the Guam Procurement Regulations.
- [X] 6. **COMPLIANCE WITH SPECIFICATIONS AND OTHER SOLICITATION REQUIREMENTS:** Bidders shall comply with all specifications and other requirements of the Solicitation.
- [] 7. **“ALL OR NONE” BIDS:** Unless otherwise allowed under this Solicitation. “all or none” bids may be deemed to be non-responsive. If the bid is so limited, the Government may reject part of such proposal and award on the remainder.
- NOTE:** By checking this item, the Government is requesting all of the bid items to be bid or none at all. **The Government will not award on an itemized basis.** Reference: Section 3-101.06 of the Guam Procurement Regulations.
- [X] 8. **INDEPENDENT PRICE DETERMINATION:** The bidder, upon signing the Invitation for Bid, certifies that the prices in his bid were derived at without collusion, and acknowledge that collusion and anti-competitive practices are prohibited by law. Violations will be subject to the provision of Section 5651 of that of the Guam Procurement Act. Other existing civil, criminal or administrative remedies are not impaired and may be in addition to the remedies in Section 5651 of the Government code.
- [X] 9. **BIDDER’S PRICE:** The Government will consider not more than two (2) (Basic and Alternate) item prices and the bidder shall explain fully each price if supplies, materials, equipment, and/or specified services offered comply with specifications and the products origin. Where basic or alternate bid meets the minimum required specification, cost and other factors will be considered. Failure to explain this requirement will result in rejection of the bid.
- [X] 10. **BID ENVELOPE:** Envelope shall be sealed and marked with the bidder’s name, Bid number, time, date and place of Bid Opening.
- [X] 11. **BID GUARANTEE REQUIREMENT:** Bidder is required to submit a Bid Guarantee Bond or standby irrevocable Letter of Credit or Certified Check or Cashier’s Check in the same bid envelope to be held by the Government pending award. The Bid Guarantee Bond, Letter of Credit, Certified Check or Cashier’s Check must be issued by any local surety or banking institution licensed to do business on Guam and made payable to the Guam Power Authority in the amount of fifteen percent (15%) of his highest total bid offer. The Bid Bond must be submitted on Government Standard Form BB-1 (copy enclosed). Personal Checks will not be accepted as Bid Guarantee. If a successful Bidder (contractor) withdraws from the bid or fails to enter into contract within the prescribed time, such Bid guarantee will be forfeited to the Government of Guam. Bids will be disqualified if not accompanied by Bid Bond, Letter of Credit, Certified Check or Cashier’s check. Bidder must include in his/her bid, valid copies of a Power of Attorney from the Surety and a Certificate of Authority from the Government of Guam to show proof that the surety company named on the bond instrument is authorized by the Government of Guam and qualified to do business on Guam. For detailed information on bonding matters, contact the Department of Revenue and Taxation. Failure to submit a valid Power of Attorney and Certificate of Authority on the surety is cause for rejection of bid. (GPR Section 3-202.03.3) **Pursuant to Public Law 27-127, all competitive sealed bidding for the procurement of supplies or services exceeding \$25,000.00 a 15% Bid Security of the total bid price must accompany the bid package.**
- [X] 12. **PERFORMANCE BOND REQUIREMENT:** The Bidder may be required to furnish a Performance Bond on Government Standard Form BB-1 or standby irrevocable Letter of Credit or Certified Check or Cashier’s Check payable to the Guam Power Authority issued by any of the local Banks or Bonding Institution in the amount equal to ONE HUNDRED PERCENT (100%) of the contract prices as security for the faithful performance and proper fulfillment of the contract. In the event that any of the provisions of this contract are

violated by the contractor, the Chief Procurement Officer shall serve written notice upon both the contractor and the Surety of its intention to terminate the contract. Unless satisfactory arrangement or correction is made within ten (10) days of such notice the contract shall cease and terminate upon the expiration of the ten (10) days. In the event of any such termination, the Chief Procurement Officer shall immediately serve notice thereof upon the Surety. The Surety shall have the right to take over and perform the contract, provided, however, that if the Surety does not commence performance thereof within 10 days from the date of the mailing of notice of termination, the Government may take over and prosecute the same to complete the contract or force account for the account and at the expense of the contractor, and the contractor and his Surety shall be liable to the Government for any excess cost occasioned the Government thereby (GPR Section 3-202.03.4).

- [X] 13. **PERFORMANCE GUARANTEE:** Bidders who are awarded a contract under this solicitation, guarantee that goods will be delivered or required services performed within the time specified. Failure to perform the contract in a satisfactory manner may be cause for suspension or debarment from doing business with the Government and to enforce Section 23 of these General Terms and Conditions. In addition, the Government will hold the Vendor liable and will enforce the requirements as set forth in Section 41 of these General Terms and Conditions.
- [X] 14. **SURETY BONDS:** Bid and Performance Bonds coverage must be signed or countersigned in Guam by a foreign or alien surety's resident general agent. The surety must be an Insurance Company, authorized by the government of Guam and qualified to do business in Guam. Bids will be disqualified if the Surety Company does not have a valid Certificate of Authority from the Government of Guam to conduct business in Guam.
- [X] 15. **COMPETENCY OF BIDDERS:** Bids will be considered only from the such bidders who, in the opinion of the Government, can show evidence of their ability, experience, equipment, and facilities to render satisfactory service.
- [X] 16. **DETERMINATION OF RESPONSIBILITY OF BIDDERS:** The Chief Procurement Officer reserves the right for securing from bidders information to determine whether or not they are responsible and to inspect plant site, place of business; and supplies and services as necessary to determine their responsibility in accordance with Section 15 of these General Terms and Conditions (GPR Section 3-401).
- [X] 17. **STANDARD FOR DETERMINATION OF LOWEST RESPONSIBLE BIDDER:** In determining the lowest responsible offer, the Chief Procurement Officer shall be guided by the following:
- a) Price of items offered.
 - b) The ability, capacity, and skill of the Bidder to perform.
 - c) Whether the Bidder can perform promptly or within the specified time.
 - d) The quality of performance of the Bidder with regards to awards previously made to him.
 - e) The previous and existing compliance by the Bidder with laws and regulations relative to procurement.
 - f) The sufficiency of the financial resources and ability of the Bidder to perform.
 - g) The ability of the bidder to provide future maintenance and services for the subject of the award.
 - h) **The compliance with all of the conditions to the Solicitation.**
- [X] 18. **TIE BIDS:** If the bids are for the same unit price or total amount in the whole or in part, the Chief Procurement Officer will determine award based on Section 3.202.15.2, or to reject all such bids (GPR Section 3-202.15.2).
- [] 19. **BRAND NAMES:** Any reference in the Solicitation to manufacturer's Brand Names and number is due to lack of a satisfactory specification of commodity description. Such preference is intended to be descriptive, but not restrictive and for the sole purpose of indicating prospective bidders a description of the article or services that will be satisfactory. Bids on comparable items will be considered provided the bidder clearly states in his bid the exact articles he is offering and how it differs from the original specification.
- [] 20. **DESCRIPTIVE LITERATURE:** Descriptive literature(s) as specified in this solicitation must be furnished as a part of the bid and must be received at the date and time set for opening Bids. The literature furnished must clearly identify the item(s) in the Bid. The descriptive literature is required to establish, for the purpose of evaluation and award, details of the product(s) the bidder proposes to furnish including design, materials, components, performance characteristics, methods of manufacture, construction, assembly or other characteristics which are considered appropriate. Rejection of the Bid will be required if the descriptive literature(s) do not show that the product(s) offered conform(s) to the specifications and other requirements of this solicitation. Failure to furnish the descriptive literature(s) by the time specified in the Solicitation will require rejection of the bid.
- [] 21. **SAMPLES:** Sample(s) of item(s) as specified in this solicitation must be furnished as a part of the bid and must be received at the date and time set for opening Bids. The sample(s) should represent exactly what the bidder proposes to furnish and will be used to determine if the item(s) offered complies with the specifications. Rejection of the Bid will be required if the sample(s) do not show that the product(s) offered conform(s) to the specifications and other requirements of this solicitation. Failure to furnish the sample(s) by the time specified in the Solicitation will require rejection of the Bid.
- [] 22. **LABORATORY TEST:** Successful bidder is required to accompany delivery of his goods with a Laboratory Test Report indicating that the product he is furnishing the Government meets with the specifications. This report is on the bidder's account and must be from a certified Testing Association.
- [X] 23. **AWARD, CANCELLATION, & REJECTION:** Award shall be made to the lowest responsible and responsive bidder, whose bid is determined to be the most advantageous to the Government, taking into consideration the evaluation factors set forth in this solicitation. No other factors or criteria shall be used in the evaluation. The right is reserved as the interest of the Government may require to waive any minor irregularity in bid received. The Chief Procurement Officer shall have the authority to award, cancel, or reject bids, in whole or in part for any one or more items if he determines it is in the public interest. Award issued to the lowest responsible bidder within the specified time for acceptance as indicated in the solicitation, results in a bidding contract without further action by either party. In case of an error in the extension of prices, unit price will govern. It is the policy of the Government to award contracts to qualified local bidders. The government reserves the right to increase or decrease the quantity of the items for award and make additional awards for the same type items and the vendor

agrees to such modifications and additional awards based on the bid prices for a period of thirty (30) days after original award. No. award shall be made under this solicitation which shall require advance payment or irrevocable letter of credit from the government (GPR Section 3-202.14.1).

- [X] 24. **MARKING:** Each outside container shall be marked with the Purchase Order number, item number, brief tem description and quantity. Letter marking shall not be less than 3/4" in height.
- [X] 25. **SCHEDULE FOR DELIVERY:** Successful bidder shall notify the Guam Power Authority Dededo Warehouse at (671) 653-2073 and/or Guam Power Authority Cabras Warehouse at (671) 475-3319, at least twenty-four (24) hours before delivery of any item under this solicitation.
- [] 26. **BILL OF SALE:** Successful supplier shall render Bills of Sale for each item delivered under this contract. Failure to comply with this requirement will result in rejection of delivery. The Bill of Sale must accompany the items delivered but will not be considered as an invoice for payment. Supplier shall bill the Government in accordance with billing instructions as indicated on the Purchase Order.
- [] 27. **MANUFACTURER'S CERTIFICATE:** Successful bidder is required, upon delivery of any item under this contract, to furnish a certificate from the manufacturer indication that the goods meet the specifications. Failure to comply with this request will result in rejection of delivery payment. Supplier shall bill the Government in accordance with billing instructions as indicated on the Purchase Order.
- [X] 28. **INSPECTION:** All supplies, materials, equipment, or services delivered under this contract shall be subject to the inspection and/or test conducted by the Government at destination. If in any case the supplies, materials, equipment, or services are found to be defective in material, workmanship, performance, or otherwise do not conform with the specifications, the Government shall have the right to reject the items or require that they be corrected. The number of days required for correction will be determined by the Government.
- [] 29. **MOTOR VEHICLE SAFETY REQUIREMENTS:** The Government will only consider Bids on motor vehicles which comply with the requirements of the National Traffic and Motor Vehicle safety Act of 1966 (Public Law 89-563) and Clean Air Act as amended (Public Law 88-206), that are applicable to Guam. Bidders shall state if the equipment offered comply with these aforementioned Federal Laws.
- [] 30. **SAFETY INSPECTION:** All motor vehicles delivered under this contract must pass the Government of Guam Vehicle Inspection before delivery at destination.
- [] 31. **GUARANTEE:**
- a) **Guarantee of Vehicle Type of Equipment:**
The successful bidder shall guarantee vehicular type of equipment offered against defective parts, workmanship, and performance, for a period of not less than one (1) year after date of receipt of equipment. Bidder shall also provide service to the equipment for at least one (1) year. Service to be provided shall include, but will not be limited to tune ups (change of spark plugs, contact points and condensers) and lubrication (change of engine and transmission oil). All parts and labor shall be at the expense of the bidder. All parts found defective and not caused by misuse, negligence or accident within the guarantee period shall be repaired, replaced, or adjusted within six (6) working days after notice from the Government and without cost to the Government. Vehicular type of equipment as used in this context shall include equipment used for transportation as differentiated from tractors, backhoes, etc.
- b) **Guarantee of Other Type of Equipment:**
The successful bidder shall guarantee all other types of equipment offered, except those mentioned in 31a, above, against defective parts, workmanship, and performance for a period of not less than three (3) months after date of receipt of equipment. Bidder shall also provide service to the equipment for at least three (3) months. All parts found defective within that period shall be repaired or replaced by the Contractor without cost to the Government. Repairs, adjustments or replacements of defective parts shall be completed by the contractor within six (6) working days after notice from the Government.
- c) **Compliance with this Section is a condition of this Bid.**
- [X] 32. **REPRESENTATION REGARDING ETHICS IN PUBLIC PROCUREMENT:** The bidder or contractor represents that it has not knowingly influenced and promises that it will not knowingly influence a Government employee to breach any of the ethical standards and represents that it has not violated, is not violating, and promises that it will not violate the prohibition against gratuities and kickbacks set forth on Chapter 11 (Ethics in Public Contracting) of the Guam Procurement Act and in Chapter 11 of the Guam Procurement Regulations.
- [X] 33. **REPRESENTATION REGARDING CONTINGENT FEES:** The contractor represents that it has not retained a person to solicit or secure a Government contract upon an agreement or understanding for a commission, percentage, brokerage, or contingent fee, except for retention of bona fide employees or bona fide established commercial selling agencies for the purpose of securing business (GPR Section 11-207).
- [X] 34. **EQUAL EMPLOYMENT OPPORTUNITY:** Contractors shall not discriminate against any employee or applicant of employment because of race, color, religion, se, or national origin. The contractor will take affirmative action to ensure that employees are treated equally during employment without regards to their race, color, religion, sex, or national origin.
- [X] 35. **COMPLIANCE WITH LAWS:** Bidders awarded a contract under this Solicitation shall comply with the applicable standard, provisions, and stipulations of all pertinent Federal and/or local laws, rules, and regulations relative to the performance of this contract and the furnishing of goods.
- [] 36. **CHANGE ORDER:** Any order issued relative to awards made under this solicitation will be subject to and in accordance with the provisions of Section 6-101-03.1 of the Guam Procurement Regulations.
- [] 37. **STOP WORK ORDER:** Any stop work order issued relative to awards made under this solicitation will be subject to and in accordance with the provisions of Section 6-101-04.1 of the Guam Procurement Regulations.

- [] 38. **TERMINATION FOR CONVENIENCE:** Any termination order for the convenience of the Government issued relative towards made under this solicitation will be subject to and in accordance with the provisions of Section 6-101.10 of the Government Procurement Regulations.

- [X] 39. **TIME FOR COMPLETION:** It is hereby understood and mutually agreed by and between the contractor and the Government that the time for delivery to final destination or the timely performance of certain services is an essential condition of this contract. If the contractor refuses or fails to perform any of the provisions of this contract within the time specified in the Purchase Order (from the date Purchase Order is acknowledged by vendor), then the contractor is in default. Defaults will be treated subject to and in accordance with the provisions of Section 6-101-08 of the Guam Procurement Regulations.

- [X] 40. **JUSTIFICATION OF DELAY:** Bidders who are awarded contracts under this Solicitation, guarantee that the goods will be delivered to their destination or required services rendered within the time specified. If the bidder is not able to meet the specified delivery date, he is required to notify the Chief Procurement Officer of such delay. Notification shall be in writing and shall be receive by the Chief Procurement Officer at least twenty-four (24) hours before the specified delivery date. Notification of delay shall include an explanation of the causes and reasons for the delay including statement(s) from supplier or shipping company causing the delay. The Government reserves the right to reject delay justification if, in the opinion of the Chief Procurement Officer, such justification is not adequate.

- [X] 41. **LIQUIDATED DAMAGES:** When the contractor is given notice of delay or nonperformance as specified in Paragraph 1 (Default) of the Termination for Default Clause of this contract and fails to cure in the time specified, the contractor shall be liable for damages for delay in the amount of one-fourth of one percent (1%) of outstanding order per calendar day from date set for cure until either the territory reasonable obtains similar supplies or services if the contractor is terminated for default, or until the contractor provides the supplies or services if the contractor is not terminated for default. To the extent that the contractor's delay or nonperformance is excused under Paragraph 40 (Excuse for Nonperformance or Delayed Performance) of the Termination for Default Clause of this contract, liquidated damages shall not e due the territory. The contractor remains liable for damages caused other than by delay (GPR Section 6-101-09.1).

- [X] 42. **PHYSICAL LIABILITY:** If it becomes necessary for the Vendor, either as principal, agent or employee, to enter upon the premises or property of the Government of Guam in order to construct, erect, inspect, make delivery or remove property hereunder, the Vendor hereby covenants and agrees to take, use, provide and make all proper, necessary and sufficient precautions, safeguards and protections against the occurrence of any accidents, injuries or damages to any person or property during the progress of the work herein covered, and to be responsible for, and to indemnify and save harmless the Government of Guam from the payment of all sums of money by reason of all or any such accidents, injuries or damages that may occur upon or about such work, and fines, penalties and loss incurred for or by reasons of the violations of any territorial ordinance, regulations, or the laws of Guam or the United States, while the work is in progress. Contractor will carry insurance to indemnify the Government of Guam against any claim for loss, damage or injury to property or persons arising out of the performance of the Contractor or his employees and agents of the services covered by the contract and the use, misuse or failure of any equipment used by the contractor or his employees or agents, and shall provide certificates of such insurance to the Government of Guam when required.

- [X] 43. **CONTACT FOR CONTRACT ADMINISTRATION:** If your firm receives a contract as a result of this Solicitation, please designate a person whom we may contact for prompt administration.

Name: _____ Title: _____

Address: _____ Telephone: _____

GOVERNMENT OF GUAM

SEALED BID SOLICITATION INSTRUCTIONS

1. **BID FORMS:** Each bidder shall be provided with two (2) sets of Solicitation forms. Additional copies may be provided upon request. Bidders requesting additional copies of said forms will be charged per page in accordance with Section 6114 of the Government Code of Guam. All payments for this purpose shall be by cash, certified check or money order and shall be made payable to the Guam Power Authority.

2. **PREPARATIONS OF BIDS:**
 - a) Bidders are required to examine the drawings, specifications, schedule, and all instructions. Failure to do so will be at bidder's risk.
 - b) Each bidder shall furnish the information required by the Solicitation. The bidder shall sign the solicitation and print or type his name on the Schedule. Erasures or other changes must be initialed by the person signing the bid. Bids signed by an agent are to be accompanied by evidence of this authority unless such evidence has been previously furnished to the issuing office.
 - c) Unit price for each unit offered shall be shown and such price shall include packing unless otherwise specified. A total shall be entered in the amount column of the Schedule for each item offered. In case of discrepancies between a unit price and extended price, the unit price will be presumed to be correct.
 - d) Bids for supplies or services other than those specified will not be considered. Time, if stated as a number of days, means calendar days and will include Saturdays, Sundays, and holidays beginning the day after the issuance of a Notice to Proceed. Time stated ending on a Saturday, Sunday or Government of Guam legal holiday will end at the close of the next business day.

3. **EXPLANATION TO BIDDERS:** Any explanation desired by a bidder regarding the meaning or interpretation of the Solicitation, drawings, specifications, etc., must be submitted in writing and with sufficient time allowed for a written reply to reach all bidders before the submission of their bids. Oral explanations or instructions given before the award of the contract will not be binding. Any information given to a prospective bidder concerning a Solicitation will be furnished to all prospective bidders in writing as an amendment to the Solicitation if such information would be prejudicial to uninformed bidders.

4. **ACKNOWLEDGEMENT OF AMENDMENTS TO SOLICITATIONS:** Receipt of an amendment to a Solicitation by a bidder must be acknowledged by signing an acknowledgement of receipt of the amendment. Such acknowledgement must be received prior to the hour and date specified for receipt of bids.

5. **SUBMISSION OF BIDS:**
 - a) Bids and modifications thereof shall be enclosed in sealed envelopes and addressed to the office specified in the Solicitation. The bidder shall show the hour and date specified in the Solicitation for receipt, the Solicitation number, and the name and address of the bidder on the face of the envelope.
 - b) Telegraphic bids will not be considered unless authorized by the Solicitation. However, bids may be modified or withdrawn by written or telegraphic notice, provided such notice is received prior to the hour and date specified for receipt (see paragraph 6 of these instructions).
 - c) Samples of items, when required, must be submitted within the time specified, unless otherwise specified by the Government, at no expense to the Government. If not destroyed by testing, samples will be returned at bidder's request and expense, unless otherwise specified by the Solicitation.
 - d) Samples or descriptive literature should not be submitted unless it is required on this solicitation. Regardless of any attempt by a bidder to condition the bid, unsolicited samples or descriptive literature will not be examined or tested at the bidder's risk, and will not be deemed to vary any of the provisions of this Solicitation.

6. **FAILURE TO SUBMIT BID:** If no bid is to be submitted, do not return the solicitation unless otherwise specified. A letter or postcard shall be sent to the issuing office advising whether future Solicitations for the type of supplies or services covered by this Solicitation are desired.

7. **LATE BID, LATE WITHDRAWALS, AND LATE MODIFICATIONS:**
 - a) Definition: Any bid received after the time and date set for receipt of bids is late. Any withdrawal or modification of a bid received after the time and date set for opening of bids at the place designated for opening is late (Guam Procurement Regulations Section 3-202)
 - b) Treatment: No late bid, late modification, or late withdrawal will be considered unless received before contract award, and the bid, modification, or withdrawal would have been timely but for the action or inaction of territorial personnel directly serving the procurement activity.

8. **DISCOUNTS:**
 - a) Notwithstanding the fact that prompt payment discounts may be offered, such offer will not be considered in evaluating bids for award unless otherwise specified in the Solicitation. However, offered discounts will be taken if payment is made within the discount period, even though not considered in the evaluation of bids.

 - b) In connection with any discount offered, time will be computed from date of delivery and acceptance of the supplies to the destination as indicated in the purchase order or contract. Payment is deemed to be made for the purpose of earning the discount on the date of mailing of the Government check.

9. **GOVERNMENT FURNISHED PROPERTY:** No material, labor or facilities will be furnished by the Government unless otherwise provided for in the Solicitation.
10. **SELLERS' INVOICES:** Invoices shall be prepared and submitted in quadruplicate (one copy shall be marked "original") unless otherwise specified. Invoices shall be "certified true and correct" and shall contain the following information: Contract and order number (if any), item numbers, description of supplies or services, sizes, quantities, unit prices, and extended total. Bill of lading number and weight of shipment will be shown for shipments made on Government bills of lading.
11. **RECEIPT, OPENING AND RECORDING OF BIDS:** Bids and modifications shall be publicly opened in the presence of one or more witnesses, at the time, date, and place designated in the Invitation for Bids. The name of each bidder, the bid price, and such other information as is deemed appropriate by the Procurement Officer, shall be read aloud and recorded, or otherwise made available. The names and addresses of required witnesses shall be recorded at the opening. The opened bids shall be available for public inspection except to the extent the bidder designates trade secrets or other proprietary data to be confidential as set forth in accordance with Section 12 below. Material so designated shall accompany the bid and shall be readily separable from the bid in order to facilitate public inspection of the non-confidential portion of the bid. Prices, makes and models or catalogue numbers of the items offered, deliveries, and terms of payment shall be publicly available at the time of bid opening regardless of any designation to the contrary (Guam Procurement Regulations Section 3-202.12.2).
12. **CONFIDENTIAL DATA:** The Procurement Officer shall examine the bids to determine the validity of any requests for nondisclosure of trade secrets and other proprietary data identified in writing. If the parties do not agree as to the disclosure of data, the Procurement Officer shall inform the bidders in writing what portions of the bid will be disclosed and that, unless the bidders protest under Chapter 9 of the Guam Procurement Act (P.L. 16-124), the bids will be so disclosed. The bids shall be opened to public inspection subject to any continuing prohibition on the disclosure of confidential data (Guam Procurement Regulations Section 3-202.12.3).
13. **MULTI-STEP SEALED BIDDING:**
- a. It is defined as two-phase process consisting of a technical first-phase composed of one or more steps in which bidders submit unpriced technical offers to be evaluated by the territory, and a second-phase in which those bidders whose technical offers are determined to be acceptable during the first-step have their priced bids considered. It is designed to obtain the benefits of competitive sealed bidding by award of a contract to the lowest responsive, responsible bidder, and at the same time obtained the benefits of the competitive sealed proposals procedure through the solicitation of technical offers and the conduct of discussions to evaluate and determine the acceptability of technical offers.
 - b. In addition to the requirements set forth in the General Terms and Conditions and the Special provisions, the following applies:
 - 1). only unpriced technical offers are requested in the first phase;
 - 2). priced bids will be considered only in the second phase and only from bidders whose unpriced technical offers are found acceptable in the first phase;
 - 3). the criteria to be used in the evaluation at those specified in the Special Provisions and the General Terms and Conditions;
 - 4). the territory, to the extent the Procurement Officer finds necessary, may conduct oral or written discussion of the unpriced technical offers;
 - 5). the bidders, may designate those portions of the unpriced technical offers which contain trade secrets or other proprietary data which are to remain confidential; and,
 - 6). the service being procured shall be furnished generally in accordance with bidder's technical offer as found to be finally acceptable and shall meet the requirements of the Invitation for Bids.
 - c. **RECEIPT AND HANDLING OF UNPRICED TECHNICAL OFFERS.**
Unpriced technical offers shall not be opened publicly, but shall be opened in front of two or more procurement officials. Such offers shall not be disclosed to unauthorized persons. Bidders may request nondisclosure of trade secrets and other proprietary data identified in writing.
 - d. **EVALUATION OF UNPRICED TECHNICAL OFFERS.**
The unpriced technical offers submitted by bidders shall be evaluated solely in accordance with the criteria set forth in the Invitation for Bids. The unpriced technical offers shall be categorized as:
 - 1). acceptable;
 - 2). potentially acceptable, that is, reasonably susceptible of being made acceptable; or
 - 3). unacceptable. The Procurement Officer shall record in writing the basis for finding an offer unacceptable and make it part of the procurement file.

The Procurement Officer may initiate Phase Two of the procedure if, in the Procurement Officer's opinion, there are sufficient acceptable unpriced technical offers to assure effective price competition in the second phase without technical discussions. If the Procurement Officer finds such is not the case, the Procurement Officer shall issue an amendment to the Invitation for Bids or engage in technical discussions as set forth in Subsection 3-202.20.5 of this Section.
 - e. Upon the completion of Phase One, the Procurement Officer shall invite each acceptable bidder to submit a price bid. Upon submission of prices, the Procurement Officer shall prepare the final evaluation and reconsideration for the Chief Procurement Officer's approval.