



GUAM POWER AUTHORITY
AGANA, GUAM

SPECIFICATION No. E-010

REVISION: 2
May 21, 2010

PREPARED BY THE ENGINEERING DEPT.

GUAM POWER AUTHORITY
P.O. BOX 2977
AGANA, GUAM 96932

TRANSMISSION & DISTRIBUTION SPECIFICATION

SPECIFICATION NO. E-010

FOR

FASTENER HARDWARES

EFFECTIVE DATE: 5/21/10	ISSUED: <i>[Signature]</i>	APPROVED: <i>[Signature]</i>
-------------------------	----------------------------	------------------------------



GUAM POWER AUTHORITY
AGANA, GUAM

SPECIFICATION No. E-010

PAGE 1 OF 16

REVISION: 2
May 21, 2010

PREPARED BY THE ENGINEERING DEPT.

FASTENER HARDWARES

TABLE OF CONTENTS

SECTION		PAGE
1.0	Scope	2
2.0	Applicable Publication.....	2
3.0	Deviations and Non-conformance Requirements.....	2
4.0	Submittals	3
5.0	Design	3
6.0	Construction.....	3
7.0	Machine Bolt	4
8.0	Durium Bolt.....	5
9.0	Double Arming Bolt.....	6
10.0	Double Arming Eye Bolt.....	7
11.0	Lag Screw.....	8
12.0	Square washer And Square Curve Washer.....	9
13.0	Flat Round Washer.....	10
14.0	Square Nut.....	11
15.0	Shear Bolt.....	12
16.0	Eye Nut.....	13
17.0	Thimble Eye Nut, Straight.....	14
18.0	Thimble Eye Nut, Angle.....	15
19.0	Quality Control.....	16
20.0	Packing & Shipping.....	16

EFFECTIVE DATE:

5/21/11

ISSUED:

APPROVED:



1.0 SCOPE

- 1.1 This specification covers GPA requirements for the different types of overhead line fasteners used in the Overhead Transmission and Distribution System of GPA.
- 1.2 The fasteners are intended for use in tropical weather conditions with a corrosive sea air atmosphere, sustained typhoon winds of 155mph with gusts of 180mph and subject to moderate and severe earthquakes.

2.0 APPLICABLE PUBLICATION

The fasteners shall meet the requirements of the following standards, including the latest revision with respect to material, design and tests.

- 2.1 AMERICAN NATIONAL STANDARDS INSTITUTE, INC. (ANSI) STANDARDS C135.1 and B18.2.1
- 2.2 AMERICAN SOCIETY FOR TESTING AND MATERIALS (ASTM) A153, B99.
- 2.3 INSTITUTE OF ELECTRICAL AND ELECTRONIC ENGINEERS (IEEE) C135.1-199

3.0 DEVIATIONS AND NON-CONFORMANCE REQUIREMENTS

- 3.1 Deviations from this specification or changes in the material or design after the purchase order has been placed must be approved by the GPA Engineering department and acknowledged by a Purchase Order Amendment issued by GPA.
- 3.2 Units received with deviations or non-conformances that are not acknowledged per Section 3.1 are subject to rejection. The Supplier of rejected units is responsible for any corrective action including but not limited to materials, labor and transportation necessary to dispose of or make the units conform to the specification.
- 3.3 Notification of defective units discovered before or after installation that are believed to be inherent to manufacturing problems or workmanship shall be made and forwarded to the Supplier. The description of the item, documentation of the problem and the described information, disposition and/or follow-up (as appropriate) that GPA expects from the Supplier will be specified. The Supplier's response shall be made within thirty (30) days unless an extension is acknowledged and approved in writing by the GPA Manager of Engineering.

EFFECTIVE DATE: 5/21/10

ISSUED: 

APPROVED: 



GUAM POWER AUTHORITY
AGANA, GUAM

SPECIFICATION No. E-010

PAGE 3 OF 16

REVISION: 2
May 21, 2010

PREPARED BY THE ENGINEERING DEPT.

4.0 SUBMITTALS

The offeror shall provide with their bid or proposal a written notification of any deviations from this specification. Submittals shall include product and data sheets, part numbers, a statement of compliance to this specification and other relevant information necessary to evaluate the submittal. The acceptance of GPA shall in no way abrogate the requirements of this specification.

5.0 DESIGN

Fasteners shall be designed such that they will be installed with a minimum of effort and provide optimum performance under all operating conditions.

6.0 CONSTRUCTION

- 6.1 Hardware shall be manufactured from hot rolled, open hearth, basic oxygen, or electric furnace steel, malleable type ferrous castings or other ferrous materials predetermined to be most suitable, except on item 8.0 which shall be silicon bronze as specified. Hardware shall be of the highest obtainable quality.
- 6.2 Hardware shall be hot dip galvanized to provide a continuous and lasting shield from the corrosive attack of the atmosphere and elements.
- 6.3 Hot dip galvanizing shall be after fabrication and shall be in accordance with ASTM A153 standard specification for zinc coated (hot-dip) iron and steel hard wares. All hardware shall be thoroughly cleaned, either by pickling in a dilute hot sulfuric acid solution, wheelabrating, tumbling, or sandblasting; then thoroughly rinsed and immersed in a preflux solution of zinc ammonium chloride. After drying, the hardwares shall be completely submerged in a temperature controlled molten zinc bath.
- 6.4 Hot dip galvanized threaded hardwares shall be cleaned by spinning to insure that the threads have a more than adequate coating of zinc, evenly distributed to allow finger tightening and a perfect thread fit.

EFFECTIVE DATE: 5/21/10

ISSUED: 

APPROVED: 

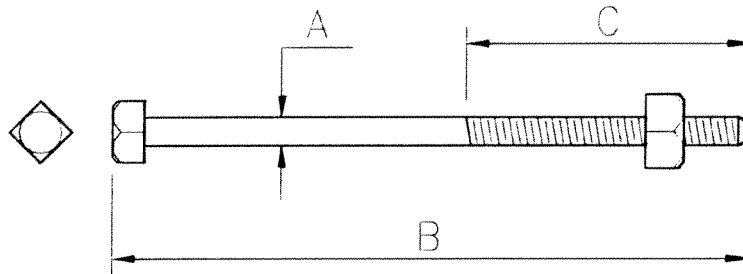

Figure A
MACHINE BOLT

7.0 MACHINE BOLT

- 7.1 Galvanized machine bolts shall have rolled threads and square head and nut.
- 7.2 Bolts shall be made with lone cone points which permit easy driving and removal without damage to the threads.
- 7.3 Dimensions and requirements are shown on Table 1.

Table 1

GPA INDEX NUMBER	DIAMETER (INCHES)	BOLT LENGTH (INCHES)	THREAD LENGTH (INCHES)	THREAD PER INCH	TENSILE STRENGTH (LBS.)
	A	B	C		
SSOB0058	3/8	2	1-3/4	16	4,250
SSOB0063	1/2	6	3	13	7,800
SSOB0065	1/2	8	4	13	7,800
SSOB0067	5/8	14	6	11	12,400
SSOB0079	5/8	24	6	11	12,400
SSOB0084	5/8	20	6	11	12,400
SSOB0061	5/8	2	1 1/2	11	12,400
SSOB0068	5/8	16	6	11	12,400
SSOB0076	3/4	30	6	10	18,350

EFFECTIVE DATE: 5/21/10 ISSUED: [Signature] APPROVED: [Signature]

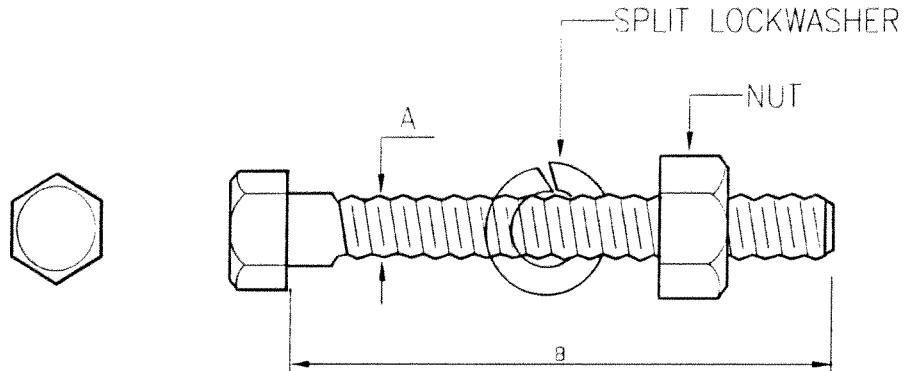

Figure B
DURIUM BOLT

8.0 DURIUM BOLT

DESIGN FEATURES

- 8.1 Durium bolts shall be fully threaded; the silicon bronze is per ASTM B99.
- 8.2 Bolts shall be furnished and assembled with a nut and split lockwasher.
- 8.3 Dimensions and requirements are shown on Table 2.

Table 2

GPA INDEX NUMBER	THREAD SIZE (INCHES)	THREAD LENGTH	WASHER (INCHES)
	A	B	
SSUB0060	1/2-13	2 inches	1/2
SSUB0061	1/2-13	3 inches	1/2

EFFECTIVE DATE: Feb 5/21/09 ISSUED: [Signature] APPROVED: [Signature]

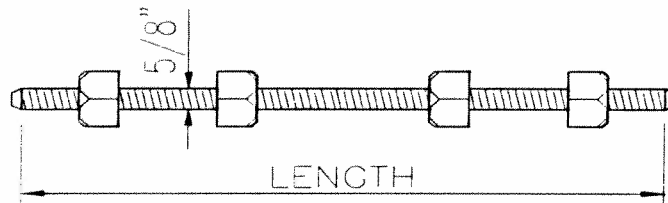

Figure C
DOUBLE ARMING BOLT

9.0 DOUBLE ARMING BOLT

DESIGN FEATURES

- 9.1 Double arming bolts shall be roll threaded, with cone points at both ends for easy driving and removal without damage to threads.
- 9.2 Bolts shall be furnished with four square nuts.
- 9.3 Dimensions and requirements are shown on Table 3.

Table 3

GPA INDEX NUMBER	DIAMETER (INCHES) A	BOLT LENGTH (INCHES) B		TENSILE STRENGTH (LBS.)
SSOB0054	5/8	20	11	12,400
SSOB0055	5/8	24	11	12,400
SSOB0056	5/8	28	11	12,400
SSOB0057	5/8	30	11	12,400
SSOB0078	5/8	32	11	12,400
SSOB0082	5/8	36	11	12,400
SSOB0077	3/4	30	10	18,350
SSOB0081	3/4	20	10	18,350
SSOB0083	3/4	36	10	18,350
SSOB0089	5/8	42	11	12,400
SSOB0090	5/8	22	11	12,400

EFFECTIVE DATE: 5/21/10

ISSUED: 

APPROVED: 

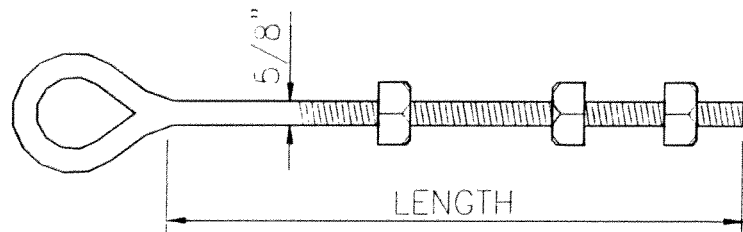

Figure D
DOUBLE ARMING EYE BOLT

10.0 DOUBLE ARMING EYE BOLT

DESIGN FEATURES

- 10.1 Double arming eye bolts shall be roll threaded, with a cone point for easy driving and removal without damage to the threads.
- 10.2 Bolts shall be furnished with three square nuts. The size of eye shall be 1-1/2" X 2".
- 10.3 Dimensions and requirements are shown on Table 4.

Table 4

GPA INDEX NUMBER	DIAMETER (INCHES) A	BOLT LENGTH (INCHES) B	THREAD LENGTH (INCHES) C	THREAD PER INCH	TENSILE STRENGTH (LBS.)
SSOB0062	5/8	16	14	11	12,400
SSOB0064	5/8	22	18	11	12,400
SSOB0059	5/8	24	22	11	12,400

EFFECTIVE DATE: 5/21/0 ISSUED: [Signature] APPROVED: [Signature]

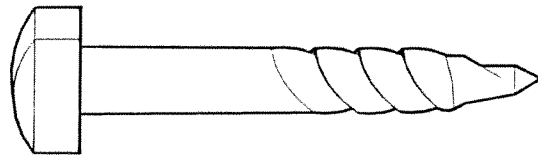

Figure E
LAG SCREW

11.0 LAG SCREW

DESIGN FEATURES

- 11.1 Lag screw shall have rolled threads and standard square heads.
- 11.2 The heads shall be an upset shoulder with the same outside mounting holes.
- 11.3 Dimensions and requirements are shown on Table 5.

Table 5

GPA INDEX NUMBER	DIAMETER (INCHES)	BOLT LENGTH (INCHES)	THREAD LENGTH (INCHES)	TENSILE STRENGTH (LBS.)
SSOL0831	1/2	4	3	6,500

EFFECTIVE DATE: 5/21/10	ISSUED: <i>feh</i>	APPROVED: <i>[Signature]</i>
-------------------------	--------------------	------------------------------

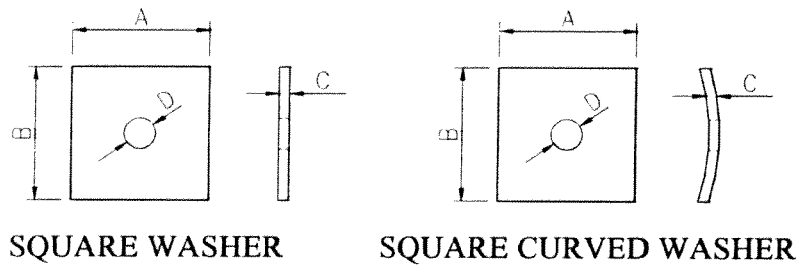

Figure F
SQUARE WASHER AND SQUARE CURVED WASHER

12.0 SQUARE WASHER AND SQUARE CURVED WASHER

DESIGN FEATURES

- 12.1 Square and square curved washers shall be provided with round holes for use with eye bolts or anchor rods on the curved surface of poles to carry heavy loads
- 12.2 All square and square curved washers are formed on a 4-3/4 inch radius.
- 12.3 Dimensions and requirements are shown on the Table 6.

Table 6

GPA INDEX NUMBER	WASHER TYPE	SIZE (INCHES)			HOLE DIAMETER (INCHES)	BOLT DIAMETER INCHES
		A	B	C	D	
SSOW1377	FLAT	2-1/2	2-1/2	3/16	11/16	5/8
SSOW1378	FLAT	2-1/2	2-1/2	3/16	13/16	3/4
SSOW1375	CURVED	2-1/2	2-1/2	3/16	11/16	5/8
SSOW1376	CURVED	2-1/2	2-1/2	3/16	13/16	3/4

EFFECTIVE DATE: 5/21/10 ISSUED: *[Signature]* APPROVED: *[Signature]*

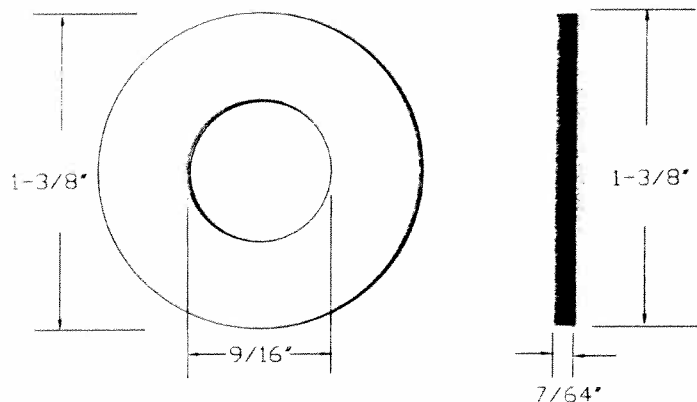

Figure G
FLAT ROUND WASHER

13.0 FLAT ROUND WASHER

DESIGN FEATURES

- 13.1 Flat Round Washer shall be galvanized steel.
- 13.2 Dimensions and requirements are shown on the Table 7.

Table 7

GPA INDEX NUMBER	WASHER TYPE (FLAT)	SIZE (INCHES)			HOLE DIAMETER (INCHES)	BOLT DIAMETER (INCHES)
		1-3/8	1-3/8	7/64		
SSOW1373	ROUND	1-3/8	1-3/8	7/64	9/16	1/2

EFFECTIVE DATE: 5/21/10 ISSUED: *[Signature]* APPROVED: *[Signature]*



GUAM POWER AUTHORITY
AGANA, GUAM

SPECIFICATION No. E-010

PAGE 11 OF 16

REVISION: 2
May 21, 2010

PREPARED BY THE ENGINEERING DEPT.

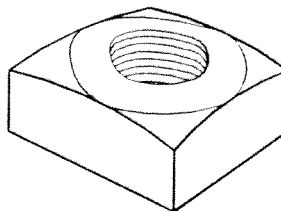

Figure H
SQUARE NUT

14.0 SQUARE NUT

DESIGN FEATURES

- 14.1 Square nuts shall be manufactured in accordance with the ANSI B18.2.2 and tapped after centrifugal hot dip galvanizing.
- 14.2 Dimensions and requirements are shown on the Table 8.

Table 8

HOLE DIAMETER (INCH)	THREADS PER (INCH)
3/8	16
1/2	13
5/8	11
3/4	10

EFFECTIVE DATE:

7/21/10

ISSUED:

7/21/10

APPROVED:

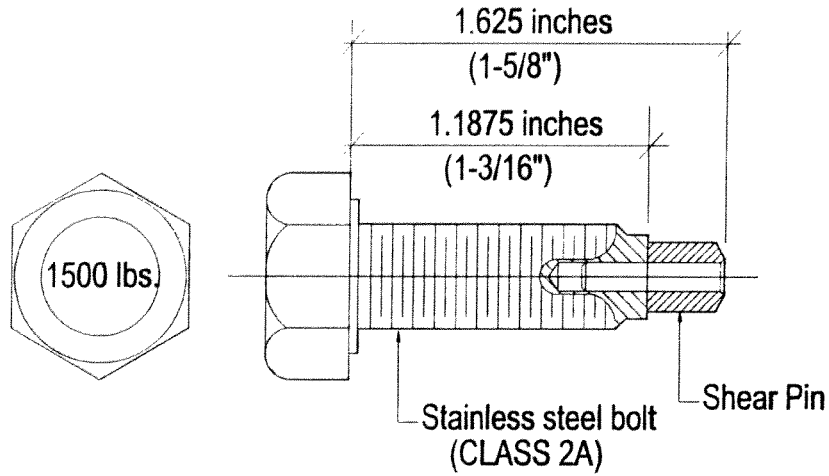

Figure I
SHEAR BOLT

15.0 SHEAR BOLT (SSOB0132)

DESIGN FEATURES

15.1 Shear bolts shall be designed to release when stresses substantially below the ultimate cantilever strength of the horizontal post insulator are imposed on it by the conductor.

15.2 Dimensions and requirements are shown in Table 9.

Table 9

GPA INDEX NUMBER	THREAD SIZE (INCHES)	SHEAR STRENGTH	INSULATOR CANTILEVER STRENGTH
SSOB0132	1.1875	1500 Lbs.	2800 Lbs.

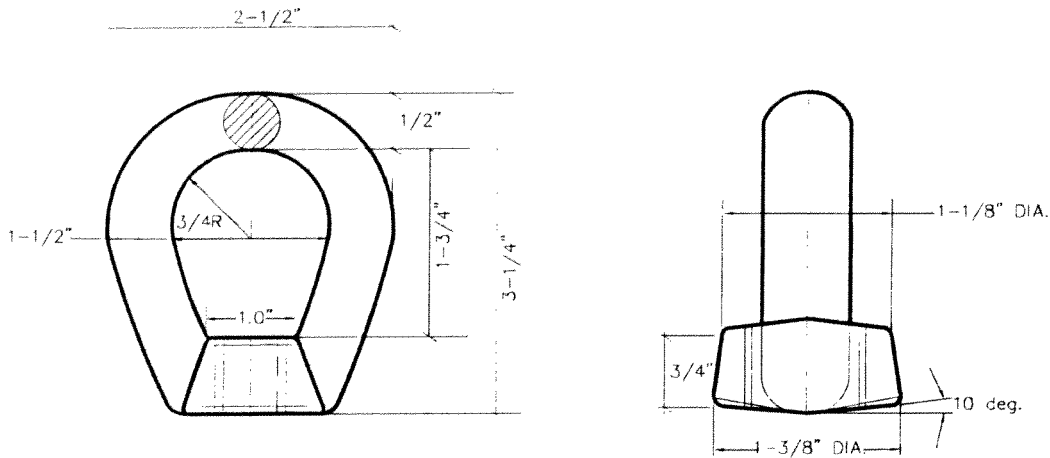

EYE NUT

Figure J
EYE NUT

16.0 EYE NUT (SSON0972)

DESIGN FEATURES

- 16.1 Standard eye nut shall fits 5/8" diameter bolts.
- 16.2 Most commonly used for deadending on the ends of crossarm bolts.
- 16.3 The material shall be drop-forged, hot dipped galvanized steel per ASTM A-153.
- 16.4 Dimensions and requirements are shown on Table 10.

Table 10

GPA INDEX NO.	DESCRIPTION	BOLT SIZE	THREAD PER INCH
SSON0972	EYE NUT	5/8"	11

EFFECTIVE DATE: 5/21/10 ISSUED: [Signature] APPROVED: [Signature]

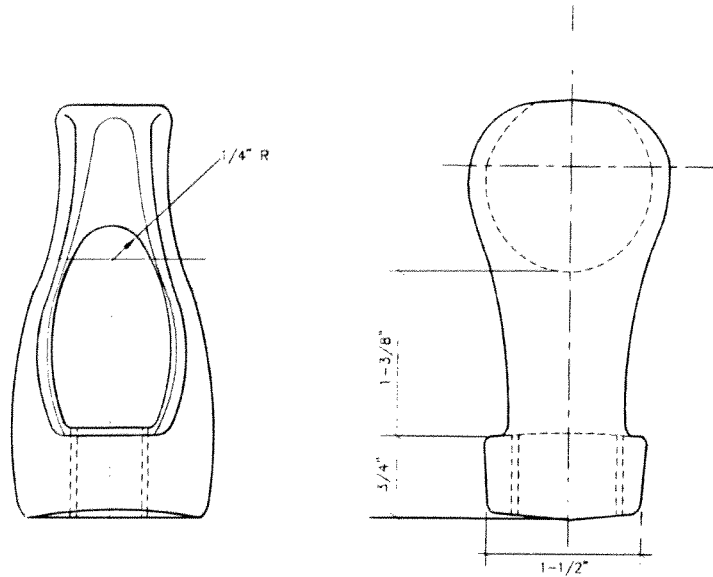

THIMBLE EYE NUT, STRAIGHT

Figure K
THIMBLE EYE NUT, STRAIGHT

17.0 THIMBLE EYE NUT, STRAIGHT (SSON0971)

DESIGN FEATURES

- 17.1 Threaded Thimble nuts shall be used for attaching to 5/8" thru-bolts.
- 17.2 The material shall be drop-forged, hot dipped galvanized steel per ASTM A-153. Nuts are contoured to minimize bending and kinking of guy strands.
- 17.3 Dimensions and requirements are shown on Table 11.

Table 11

GPA INDEX NO.	DESCRIPTION	BOLT SIZE	THREAD PER INCH
SSON0971	THIMBLE EYE NUT, STRAIGHT	5/8"	11

EFFECTIVE DATE: 5/21/10 ISSUED: 1/21/10 APPROVED: *[Signature]*

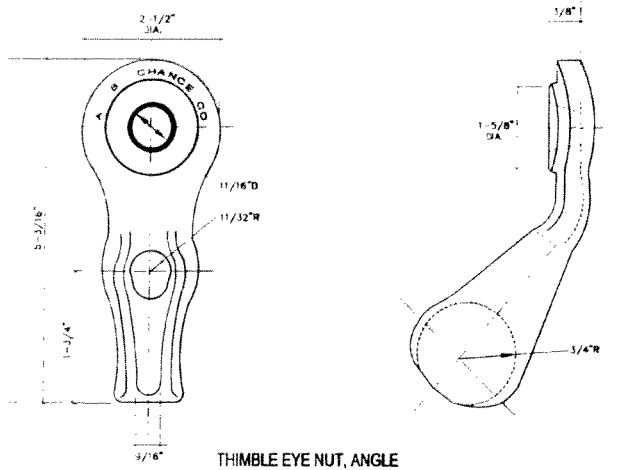

THIMBLE EYE NUT, ANGLE

Figure L
THIMBLE EYE NUT, ANGLE

18.0 THIMBLE EYE NUT, ANGLE (SSON0974)

DESIGN FEATURES

- 18.1 Angle Thimbleye shall be used for attaching to 5/8" bolts.
- 18.2 Rounded groove shall protect guy strands from sharp bending and kinking.
- 18.3 The material shall be drop-forged hot dip galvanized steel per ASTM A-153.
- 18.4 Dimensions and requirements are shown on Table 12.

Table 12

GPA INDEX NO.	DESCRIPTION	HOLE SIZE
SSON0974	THIMBLE EYE NUT, ANGLE	5/8"

EFFECTIVE DATE: 5/21/10	ISSUED: <i>[Signature]</i>	APPROVED: <i>[Signature]</i>
-------------------------	----------------------------	------------------------------



GUAM POWER AUTHORITY
AGANA, GUAM

SPECIFICATION No. E-010

PAGE 16 OF 16

REVISION: 2
May 21, 2010

PREPARED BY THE ENGINEERING DEPT.

19.0 QUALITY CONTROL

- 19.1 The supplier shall have a quality control program to ensure compliance with the requirements of this specification. The program shall be documented and available for GPA's review if requested.

Documentation of the quality control program shall indicate where in the production and manufacturing process the quality checks are taken, describe the purpose of the checks, and describe the nature of the check, e.g. if check is visual only or if electrical or mechanical testing is used.

20.0 PACKING AND SHIPPING

- 20.1 The supplier shall have adequate work and inspection instructions for handling, storage, prevention, packing and shipping to protect the quality of the connectors and to prevent damage, loss and deterioration of the material.
- 20.1 The fastener hardware shall be placed and crated with suitable materials to prevent damage and injury during shipment and handling operations.
- 20.2 The exposed threads on bundled hardware shall be protected by heavy burlap. The nuts of the bolts shall be preassembled to insure proper thread fit and provide extra protection during handling.
- 20.3 Standard packages shall be lightweight for easy handling in the warehouse, storeroom, and field.

EFFECTIVE DATE: 5/21/10	ISSUED: <i>[Signature]</i>	APPROVED: <i>[Signature]</i>
-------------------------	----------------------------	------------------------------