



GUAM POWER AUTHORITY  
AGANA, GUAM

Specification No. E-014

PAGE \_\_\_\_\_ OF \_\_\_\_\_

Rev. 2 11/21/91

PREPARED BY INFORMATION SYSTEMS DEPARTMENT

GUAM POWER AUTHORITY  
POST OFFICE BOX 2977  
AGANA, GUAM 96910

TRANSMISSION AND DISTRIBUTION

SPECIFICATION No. E-014

FOR

Miscellaneous Hardwares; Mounting

Stud Angle Brace, Staple,

Strandwise, Guy Guard

Clevis Eye Connector,

Alley Guy, Armor Rod

EFFECTIVE DATE:

SEP 21 1984

ISSUED:

*ewmy*

APPROVED:

*ABalajoshi*



GUAM POWER AUTHORITY  
AGANA, GUAM

Specification No. E-014

PAGE 1 OF 9

Rev. 2 11/21/91

PREPARED BY INFORMATION SYSTEMS DEPARTMENT

MISCELLANEOUS HARDWARES; MOUNTING STUD,  
ANGLE BRACE, STAPLE, STRANDWISE,  
GUY GUARD, CLEVIS EYE CONNECTOR,  
ALLEY GUY, ARMON ROD

TABLE OF CONTENTS

1.0	Scope
2.0	Conformance
3.0	Mounting Stud
4.0	Angle Brace
5.0	Staple
6.0	Strandwise
7.0	Guy Guard
8.0	Clevis Eye Connector
9.0	Alley Guy
10.0	Armor Rod

EFFECTIVE DATE: SEP 21 1994

ISSUED: *[Signature]*

APPROVED: *[Signature]*



GUAM POWER AUTHORITY  
AGANA, GUAM

Specification No. E-014

PAGE 2 OF 9

Rev. 2 11/21/91

PREPARED BY INFORMATION SYSTEMS DEPARTMENT

1.0 SCOPE:

To describe the design and technical features for the different type of miscellaneous hardware used in the transmission and distribution system of GPA.

2.0 CONFORMANCE TO SPECIFICATIONS:

2.1 Acceptance Requirements

2.1.1 Equipment purchased under this specification will be accepted under the requirements specified herein.

2.2 Deviations and Nonconformance Requirements

2.2.1 Deviations from this specification must be approved by the GPA Engineering Department and acknowledged on the Purchase Order by all applicable appendices to the specification.

2.2.2 Deviations from this specification or changes in the material or design after a purchase order has been placed must be approved by GPA Engineering Department and acknowledged by an appendix to the specification which shall be issued by a Purchase Order Amendment.

2.2.3 Units received with deviations from this specification not acknowledged by 2.2.1 or 2.2.2 are subject to rejection.

EFFECTIVE DATE:

SEP 21 1984

ISSUED:

*[Signature]*

APPROVED:

*[Signature]*



GUAM POWER AUTHORITY  
AGANA, GUAM

SPECIFICATION NO. E-014

PAGE 3 OF 9

REV. 2 11/21/91

PREPARED BY ENGINEERING DEPARTMENT

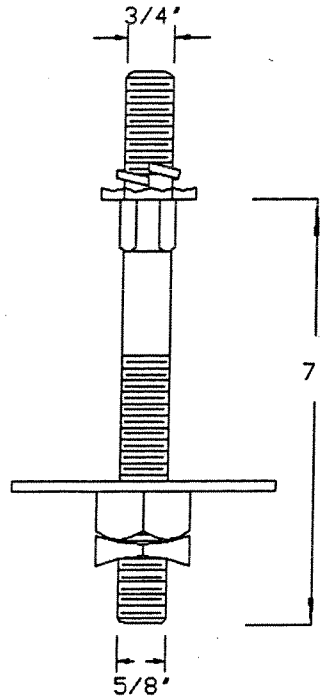

### MOUNTING STUDS

INDEX NO. S50M0953

#### 3.0 MOUNTING STUDS

##### DESIGN FEATURES

1. The mounting studs shall be made of hot dipped galvanized steel suitable for vertical line post clamp-top type insulator.
2. The studs shall be provided with 2 1/2" square washer, nut, lockwasher and locknut all hot dipped galvanized steel for wood crossarm mounting.

EFFECTIVE DATE: 11/21/91

ISSUED: 

APPROVED: 



PREPARED BY INFORMATION SYSTEMS DEPARTMENT

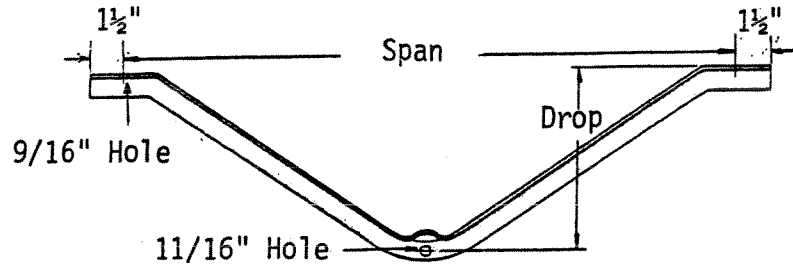

ANGLE BRACE

4.0 ANGLE BRACE:

DESIGN FEATURES

1. Brace shall be one piece, angle galvanized steel.
2. Fabrication should be in accordance with ASTM Designation A153 (Standard Specifications for Zinc Coated (Hot Dip) on Iron and Steel Hardware) of the latest revision.

<u>GPA INDEX NUMBER</u>	<u>ANGLE SIZE INCHES</u>	<u>SPAN INCHES</u>	<u>DROP INCHES</u>	<u>ARM HOLE INCHES</u>	<u>POLE HOLE INCHES</u>
SSOBO101	1 1/2 x 1 1/2 x 3/16	48	18	9/16	11/16
SSOBO102	1 3/4 x 1 3/4 x 3/16	60	18	9/16	11/16

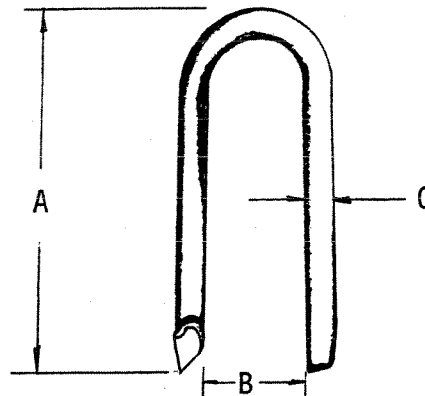

STAPLE

5.0 STAPLE:

DESIGN FEATURES

1. Staples shall be of non-rusting copper-coated metal and used for fastening mouldings and ground wires.
2. Both ends of the staple shall be cut point.
3. Dimensional requirements are shown on the table below.

GPA INDEX NO.	HEIGHT INCHES A	INSIDE WIDTH B	DIAMETER INCHES C
SSOS1311	1-3/8	1/2	.162



GUAM POWER AUTHORITY  
AGANA, GUAM

SPECIFICATION NO. E-014

PAGE 6 OF 10

REV. 2 11/21/91

PREPARED BY ENGINEERING DEPARTMENT

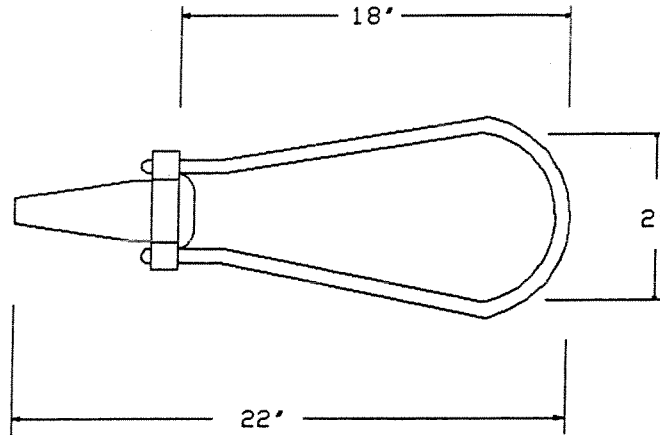

STRANDVISE

INDEX NO. SSDG0680

6.0 STRANDVISE

DESIGN FEATURES

1. The strandvise shall be made for use on 7/16" extra high strength and galvanized guy wire and type 506 strain insulator.

EFFECTIVE DATE: 11/21/91

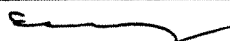
ISSUED: 

APPROVED: 

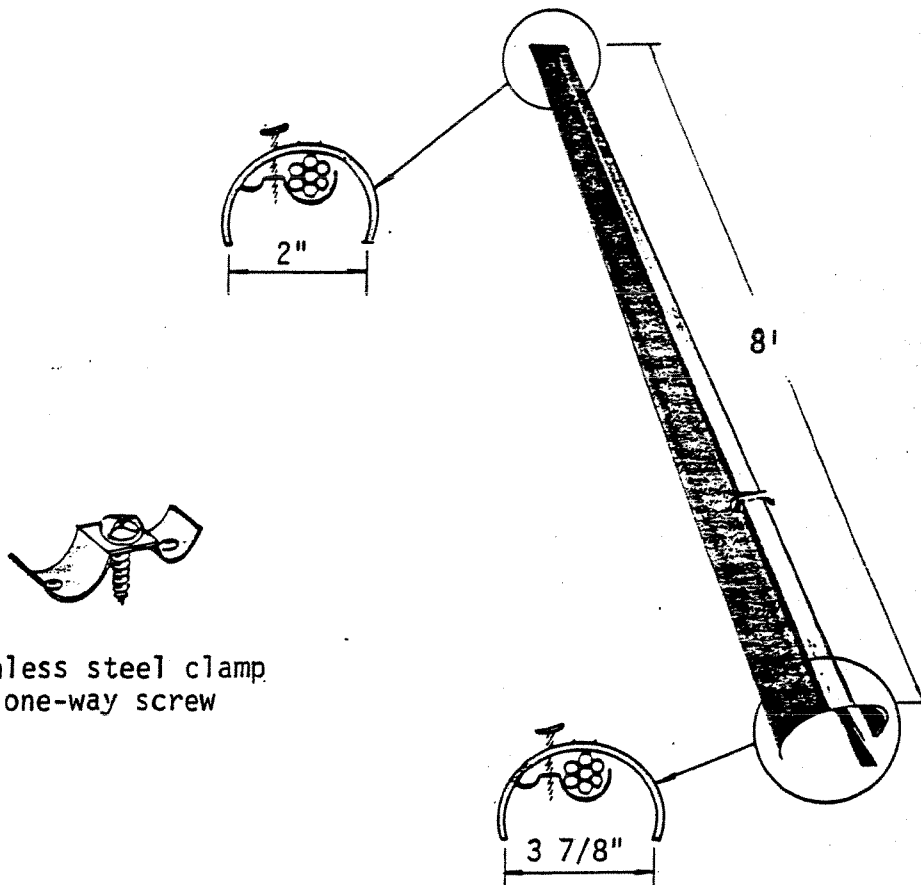

Stainless steel clamp  
with one-way screw

GUY GUARD

7.0 GUY GUARD:

DESIGN FEATURES

1. Guy guard shall be acrylic modified PVC material with color retention and high impact resistance at all temperatures.
2. Guy guard must be provided with two easy to install stainless steel clamps one each for top and bottom portions to securely attach the guy guard to the guy wire.
3. Guy guard shall be yellow and 8 ft. long.

GPA Index Number SSOGO674.



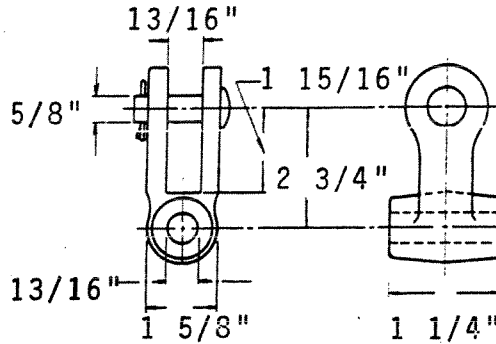

CLEVIS EYE CONNECTOR

8.0 CLEVIS EYE CONNECTOR:

DESIGN FEATURES

1. Clevis-eye connector fittings shall be AISI No. C-1038 drop forged steel and hot dip galvanized. Cotter keys shall be bronze.
2. Ultimate strength shall be 30,000 lbs heat treated.



PREPARED BY INFORMATION SYSTEMS DEPARTMENT

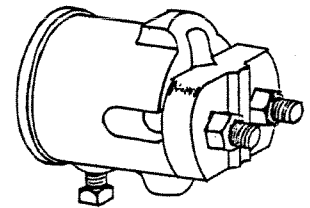
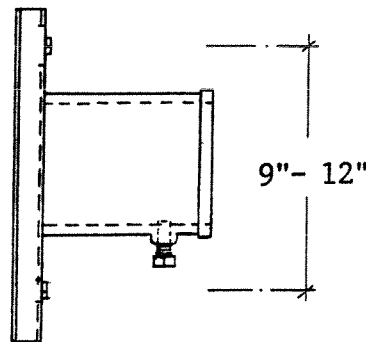
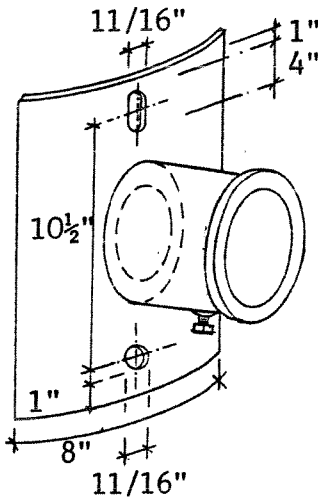
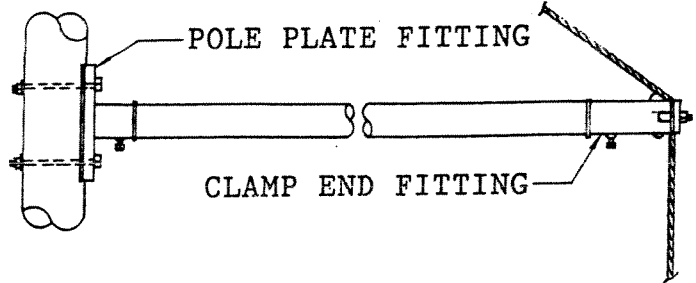
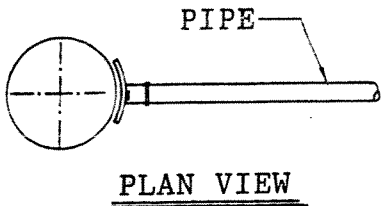

POLE PLATE FITTING

SIDE VIEW

CLAMP END FITTING

9.0 ALLEY GUY

DESIGN FEATURES

1. The pole plate and clamp end fittings must be hot dip galvanized malleable iron suitable for a 2" diameter galvanized pipe. The pole plate shall be curved.
2. The clamp end fitting must be made so that guy clamp and accessories are suitable for 7/16" diameter hot dip galvanized guy wire.
3. The pipe must be hot dip galvanized steel 2" diameter and 7' long.
4. The pole plate fitting shall be 1/4" thick and made to provide maximum surface contact with the pole to increase vertical and horizontal stability. The plate shall have one 4" key hole and one 11/16" hole for a 5/8" machine bolt.

EFFECTIVE DATE:

9/21/84

ISSUED:

APPROVED:



GUAM POWER AUTHORITY  
AGANA, GUAM

SPECIFICATION NO. E-014

PAGE 10 OF 10

REV. 2 11/21/91

PREPARED BY ENGINEERING DEPARTMENT



ARMOR ROD

10.0 ARMOR ROD

DESIGN FEATURES

1. The rod shall be made of aluminum alloy for aluminum type conductors.
2. The dimensional stability of the design shall assure lifetime dependability. The rod shall have a permanent glove-tight fit that protects and extends the conductor life expectancy.
3. The helix configuration shall remain resilient and hold securely even under severe operating conditions regardless of sag or angle.
4. The rod shall be smooth and streamlined so as not to create corona problems. Also protection from excessive clamp pressures and aeolian vibration shall assured.

INDEX NO.	CONDUCTOR ALUMINUM	CONDUCTOR DIAMETER RANGE		ROD WIRE DIA. INCHES	ROD LENGTH INCHES
		MIN.	MAX.		
SSDA0016	2/0	.447	.463	.167	54
SSDA0017	#2	.285	.296	.146	42
SSDA0018	336.4	.656	.679	.182	66
SSDA0019	927.2	1.099	1.139	.310	100

EFFECTIVE DATE: 9/25/91

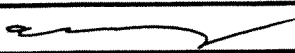
ISSUED: 

APPROVED: 